

STATE OF HAWAII  
DEPARTMENT OF TRANSPORTATION  
AIRPORTS  
HONOLULU, HAWAII

SPECIFICATIONS AND PROPOSAL  
FOR  
MAINTENANCE OF PUBLIC ADDRESS  
AND  
FLIGHT INFORMATION SYSTEMS  
HILO INTERNATIONAL AIRPORT  
HILO, HAWAII  
PROJECT NO. BH1543-53

TABLE OF CONTENTS

	PAGE
Notice to Bidders .....	NTB-1 - NTB-3
Special Provisions .....	SP-1 - SP-9
Specifications	
Section 1      Definition of Terms.....	1-1 - 1-4
Section 2      Proposal Requirements and Conditions.....	2-1 - 2-3
Section 3      Award and Execution of Contract.....	3-1 - 3-5
Section 4      Scope of Work.....	4-1 - 4-3
Section 5      Control of Work .....	5-1 - 5-3
Section 6      Control of the Material and Equipment.....	6-1 - 6-3
Section 7      Legal Relations and Responsibility.....	7-1 - 7-4
Section 8      Prosecution and Progress.....	8-1 - 8-8
Section 9      Payment.....	9-1 - 9-2
Section 10     General Requirements.....	10-1 - 10-7
Section 11     Maintenance of Public Address System.....	11-1 - 11-3
Appendix A     Equipment List .....	A-1 - A-2
Appendix B     PA / FIDS Plans .....	B-1 - B-7
Proposal .....	PF-1 - PF-6
Proposal Schedule .....	PF-7 - PF-8

**NOTICE TO BIDDERS**  
Hawaii Revised Statutes (HRS),  
Chapter 103D

The receiving of bids for MAINTENANCE OF PUBLIC ADDRESS AND FLIGHT INFORMATION SYSTEMS, HILO INTERNATIONAL AIRPORT, HILO, HAWAII, PROJECT NO. BH1543-53, will begin as of the HiePRO Release Date. Bidders shall register and submit complete bids through HiePRO only. Refer to the following HiePRO link for important information on Vendor Registration: <https://hiepro.ehawaii.gov/welcome.html>.

The solicitation plans, specifications, proposal, and additional documents designated or incorporated by reference shall be available in HiePRO.

**Bidders shall submit and upload the complete proposal to HiePRO prior to the offer due date and time. Proposals received after said due date and time shall not be considered. Any additional support documents explicitly designated as confidential and/or proprietary shall be uploaded as a separate file to HiePRO. Bidders shall not include confidential and/or proprietary documents as part of their proposal. The record of each bidder and their respective proposal shall be open to public inspection. FAILURE TO UPLOAD THE PROPOSAL TO HiePRO SHALL BE GROUNDS FOR REJECTION.**

The scope of work consists of the maintenance of the public address and flight information systems at Hilo International Airport.

To be eligible for award, bidders shall possess a valid State of Hawaii Specialty Contractors "C-13" or "C-15"), license **at the time of bidding**.

If there is a conflict between the solicitation and information stated in the pre-bid conference, the meeting minutes, and/or the responses to RFI questions, the solicitation shall govern and control, unless as amended by formal addendum.

Campaign contributions by State and County Contractors. Contractors are hereby notified of the applicability of HRS § 11-355 which states that campaign contributions are prohibited from specified State or county government contractors during the term of the contract if the contractors are paid with funds appropriated by a legislative body. For more information, contact the Campaign Spending Commission at (808) 586-0285.

Protests. Any protest of this solicitation shall be submitted in writing to the Director of Transportation, in accordance with HRS § 103D-701 and Hawaii Administrative Rules § 3-126.

The Equal Employment Opportunity Regulations of the Secretary of Labor implementing Executive Order 11246, as amended, shall be complied with on this project.

The U.S. Department of Transportation Regulation entitled “Nondiscrimination in Federally Assisted Programs of the U.S. Department of Transportation”, Title 49, Code of Federal Regulations (CFR), Part 21, is applicable to this project. Bidders are hereby notified that the Department of Transportation shall affirmatively ensure that the contract entered into pursuant to this advertisement shall be awarded to the lowest responsible bidder without discrimination on the grounds of race, color, national origin, or sex (as directed by 23 CFR Part 200).

For additional information, contact Shaun Yamaki, Project Manager, by phone at 808-838-8713, or by email at [shaun.k.yamaki@hawaii.gov](mailto:shaun.k.yamaki@hawaii.gov).

The State reserves the right to reject any or all proposals and to waive any defects in said proposals in the best interest of the public.

STATE OF HAWAII  
DEPARTMENT OF TRANSPORTATION  
AIRPORTS

SPECIAL PROVISIONS

SPECIAL PROVISIONS

The Specifications contained herein are amended as follows:

A. SECTION 1 - DEFINITION AND TERMS is amended as follows:

1. The following definition shall be deleted in its entirety and replace with the following:

"1.33 SUBCONTRACTOR - An individual, partnership, firm, corporation, joint venture or other legal entity, as licensed or required to be licensed under Chapter 444, Hawaii Revised Statutes, as amended, which enters into an agreement with the Contractor to perform a portion of the work."

2. Add the following to the end of the section:

"1.39 HAWAII ePROCUREMENT SYSTEM (HIePRO) - The State of Hawaii eProcurement System for issuing solicitations, receiving proposals and responses, and issuing notices of award."

B. SECTION 2 - PROPOSAL REQUIREMENTS AND CONDITIONS is amended as follows:

1. 2.3 PROPOSAL GUARANTY is deleted in its entirety.

2. 2.4 DELIVERY OF PROPOSALS is amended by replacing the entire subsection with:

**"2.4 DELIVERY OF PROPOSALS - Bidders shall submit and upload the complete proposal to HIePRO prior to the bid opening date and time. Proposals received after said due date and time shall not be considered. Original (wet ink, hard copy) proposal documents are not required to be submitted. Contract award shall be based on evaluation of proposals submitted and uploaded to HIePRO. Any additional support documents explicitly designated as confidential and/or proprietary shall be uploaded as a separate file to HIePRO. Do not include confidential and/or proprietary documents with the proposal. The record of each bidder and respective bid shall be open to public inspection.**

**FAILURE TO UPLOAD THE COMPLETE PROPOSAL TO HIePRO  
SHALL BE GROUNDS FOR REJECTION OF THE BID.**

If there is a conflict between the specification document and the HIePRO solicitation, the specifications shall govern and control, unless otherwise specified.

3. 2.5 WITHDRAWAL OF PROPOSALS is amended by replacing The entire subsection with:

"2.5 WITHDRAWAL OF PROPOSALS - Bids may be modified or withdrawn prior to the bid opening date and time. Withdrawal or revision of proposal shall be completed, and submitted and uploaded to HIePRO prior to the bid opening date and time."

4. 2.6 PUBLIC OPENING OF PROPOSALS is not applicable.
5. Add the following to the end of the section:

"2.9 CERTIFICATION FOR PERFORMANCE OF SERVICES - Pursuant to Section 103-55, Hawaii Revised Statutes, and unless indicated otherwise, each bidder is required to submit the attached "Certificate for Performance of Services" in the event the bidder submits a bid in excess of \$25,000.00. This certificate must be submitted to said Contracts Office, Department of Transportation, 869 Punchbowl Street, Honolulu, Hawaii 96813, upon contract execution.

As of the bid opening date, salaries of State employees performing work similar to the work called for under this contract are as follows:

<u>Class</u>	<u>Salary Range</u>	<u>Minimum Hourly Rate</u>
Electrician	BC-10	\$32.27
Electrician II (working Foreman)	WS-10	\$34.16
Automated Systems Equipment Technician	BC-14	\$37.37

Automated Systems Equipment  
Supervisor

WS-14

\$39.58

The above information is provided to the Contractor for guidance only and is subject to change in accordance with existing collective bargaining contracts or shall change as contracts are renegotiated. It is the bidder's responsibility to verify the accuracy of the wage rates contained herein and to provide for changes in the minimum wages, which must be paid personnel working on this project at all times. Information on the status of Bargaining Unit (BU) contracts can be obtained from the Airports Division, Personnel Management Office, (808) 838-8619.

Bidders are advised that they are not restricted to hire only those classifications of employees as listed, but are free to employ such other classifications of workers as the bidder deems proper and proposes to use on the project, and as may be according to the bidder's common hiring practice. However, the principal duties of employees other than those listed hereinabove working on the project will be matched against those of State workers to determine the closest equivalent State employee classification, and the Contractor must compensate such employee(s) at a rate which is no less than that of the equivalent State employee."

C. SECTION 3 - AWARD AND EXECUTION OF CONTRACT

1. 3.1 AWARD OF CONTRACT shall be amended by replacing the entire subsection with:

"3.1 AWARD OF CONTRACT - The State reserves the right to reject any and all proposals and to waive any defects as may be deemed to be in the best interest of the public.

The award of contract, if it be awarded will be made within sixty (60) calendar days after the opening of bids to the lowest responsive and responsible bidder whose proposal complies with all the prescribed requirements.

The Department may request the bidders to allow the Department to consider bids for the issuance of an award beyond the 60 calendar day period. Agreement to such an extension shall be made by a bidder in writing. Only bidders who have agreed to such an extension shall be eligible for award.

Requirement for award. The Bidder, as proof of compliance with the requirements of section 103D-310(c), HRS upon award of a contract made pursuant to Section 103D-302, HRS shall provide the documents listed below. The documents shall be submitted promptly to the Department. If a valid certificate/clearance is not submitted on a timely basis upon award, the Bidder may be deemed non-responsible"

**A. Tax Clearance.**

Pursuant to §103D-310(c), 103-53 and 103D-328, HRS, the bidder shall submit a tax clearance certificate from the State of Hawaii Department of Taxation (DOTAX) and the Internal Revenue Service (IRS), subject to Section 103D-328, HRS, current within six months of issuance date.

FORM A6, TAX CLEARANCE CERTIFICATE, is available at the following website:

<https://tax.hawaii.gov/>

To receive DOTAX Forms by fax or mail, phone (808)587-4242 or 1-800-222-3229.

The application for the Tax Clearance Certificate is the responsibility of the bidder. Bidder shall submit directly to the DOTAX or IRS. The approved certificate may then be submitted to the Department.

**B. DLIR Certificate of Compliance.**

Pursuant to §103D-310(c), HRS, the bidder shall submit a certificate of compliance for Hawaii Employment Security Law (Chapter 383, HRS), Workers' Compensation Law (Chapter 386, HRS), Temporary Disability Insurance (Chapter 392, HRS), and Prepaid Health Care Act (Chapter 393, HRS), from the State of Hawaii Department of Labor and Industrial Relations (DLIR), current within six months of issuance date.

FORM LIR#27, APPLICATION FOR CERTIFICATE OF COMPLIANCE WITH SECTION 3-122-112, HAR, is available at the following website:

<https://labor.hawaii.gov/>

Contact the DLIR Unemployment Insurance Division at (808) 586-8926 for additional information.

Inquiries regarding the status of a LIR#27 Form are available from the DLIR Disability Compensation Division at (808)586-9200.

The application for the Certificate of Compliance is the responsibility of the bidder. Bidder shall submit directly to the DLIR. The approved certificate may then be submitted to the Department.

**C. DCCA Certificate of Good Standing.**

Pursuant to §103D-310(c), HRS, the bidder shall submit a certificate of good standing from the business registration division (BREG) of the State of Hawaii Department of Commerce and Consumer Affairs (DCCA), current within six months of issuance date, to demonstrate it is either:

- (1) incorporated or organized under the laws of the State; or
- (2) registered to do business in the State as a separate branch or division that is capable of fully performing under the contract.

A Hawaii business that is a sole proprietorship, is not required to register with the BREG, and therefore not required to submit a certificate of good standing. Bidders are advised of costs associated with registering and obtaining a Certificate of Good Standing from the DCCA.

To purchase a CERTIFICATE OF GOOD STANDING, go to On-Line services at the following website:

<https://cca.hawaii.gov/>

The application for the Certificate of Good Standing is the responsibility of the bidder. Bidder shall submit directly to the DCCA. The approved certification may then be submitted to the Department.

**D.** IN LIEU OF the certificates referenced in subsection A, B, and C, bidder may make available proof of compliance through a state procurement office designated certification process."

2. The first sentence of the second paragraph of A. QUALIFICATION BEFORE BID OPENING shall be replaced with the following:

"It shall be the responsibility of the bidder to submit sufficient evidence based upon which a determination can be made by the Department that the alternate brand name is a qualified equivalent."

**D. SECTION 6 - CONTROL OF MATERIAL AND EQUIPMENT**

6.2 TRADE NAMES AND ALTERNATES is amended as follows:

- A. The first paragraph of A. QUALIFICATION BEFORE BID OPENING shall be replaced with the following:

"A. QUALIFICATION BEFORE BID OPENING - When the specifications and/or plans specify one or more manufacturer's brand names of materials or equipment to indicate a quality, style, appearance, or performance, the bidder will be assumed to have based its bid on one of the specified named products, except where such proprietary product are specified, alternate brands may be qualified if found equal or better by the Department. The bidder shall submit a request to the Department for review and approval at the earliest date possible. Requests shall be submitted via email to the Contact person listed in

HIEPRO for the solicitation and also posted as a question in HIEPRO under the question/answer tab referencing the email with the request. The request must be posted in HIEPRO no later than fourteen (14) calendar days before the bid opening date."

- B. The first sentence of the second paragraph of A. QUALIFICATION BEFORE BID OPENING shall be replaced with the following:

"It shall be the responsibility of the bidder to submit sufficient evidence based upon which a determination can be made by the Department that the alternate brand name is a qualified equivalent."

- E. SECTION 7 - LEGAL RELATIONS AND RESPONSIBILITY is amended as follows:

7.8 LABOR AND COMPENSATION REQUIREMENTS - is amended by replacing the first two paragraphs with the following:

Pursuant to Section 103-55, H.R.S., Wages, Hours, Working Conditions of Employees of Contractor's Supplying Services, services to be rendered shall be performed by employees paid at wages or salaries not less than the wages paid to public officers and employees for similar work.

Additional information on the requirements of Section 103-55, H.R.S. may be obtained at [http://www.capitol.hawaii.gov/hrscurrent/Vol102\\_Ch0046-0115/HRS0103/HRS\\_0103-0055.htm](http://www.capitol.hawaii.gov/hrscurrent/Vol102_Ch0046-0115/HRS0103/HRS_0103-0055.htm)"

Add the following subsection:

"7.10 SPECIAL REQUIREMENTS FOR CONTRACTOR'S OPERATIONS IN THE AIRPORT OPERATIONAL AREAS (AOA) - The Contractor shall conform with the applicable sections of the State Airports Program Rules and Regulations pertaining to its access and operation in the AOA hereinafter described as follows:

- A. Comprehensive General Liability Insurance - The Contractor shall obtain and maintain during the course of work, insurance coverage as specified by Section 7.9.
- B. Authorized Vehicles

1. Only vehicles considered safe and necessary for the performance of this contract shall be allowed to operate in the AOA.
  2. All authorized vehicles shall be identified with the Contractor's company name on each side with letters not less than four (4) inches in height or a logo no less than six (6) inches in height.
  3. As a condition to enter and operate in the AOA, the Contractor shall obtain insurance coverage as required by Section 7.9.
  4. The Contractor's operations on, over, across, and/or immediately adjacent to any runway and/or taxiway at a towered airport may require the use of a two-way radio communication. The Contractor shall obtain the necessary equipment at its own expense.
  5. No person shall operate a motor vehicle on the AOA without personally possessing a current Motor Vehicle Operator's Permit issued by the Airport Manager to that person.
    - a. The Motor Vehicle Operator's Permit will be issued only to persons who apply through the Airport Security Section and pass a written exam covering those portions of the Airport Rules and Regulations relating to the operation of vehicles in the AOA.
    - b. Permits issued may be suspended or revoked for cause at any time by the Airports Division.
- C. Airport Operational Area Identification Badge - Contractor's employees requiring entrance to the AOA must apply and obtain identification badges through the Airport Security Office.
1. All persons employed under this contract who have unescorted access to the AOA shall have

background checks (to the extent permitted by law) including at a minimum, references and prior employment histories by the employees relating to employment in the preceding ten (10) years.

2. As a condition in the issuance of AOA Identification Badges, Certification of Compliance shall be submitted with the application. The Certification shall affirm that a background check has been performed, correct and complete of those persons requiring access to the AOA. Background check records shall be maintained by the Contractor during the course of the work and shall contain the name, address, social security number, and previous employment and the person(s) contacted to verify such employment. The records shall be made available for inspection by the State.

F. SECTION 8 - PROSECUTION AND PROGRESS is amended as follows:

Subsection 8.2 SUBCONTRACTING is amended by adding the following sentence after the first (1<sup>st</sup>) sentence in the second (2<sup>nd</sup>) paragraph:

"The Contractor, however, shall perform with its own organization, work amounting to not less than fifty percent (50%) of the total contract cost."

G. SECTION 9 - PAYMENT is amended by adding the following subsection:

"9.6 RELEASE OF RETAINAGE - The State may release the payments withheld (retainage) at the end of one-year term provided:

- (a) The Contractor has satisfactorily fulfilled the terms and conditions of the Contract for that one-year term.
- (b) The Contractor submits a current tax clearance certificate."

STATE OF HAWAII  
DEPARTMENT OF TRANSPORTATION  
AIRPORTS

S P E C I F I C A T I O N S

SECTION 10 - GENERAL REQUIREMENTS

10.1 GENERAL - All work is subject to the requirements of Sections 1 to 9 inclusive, and this Section 10. By submitting a proposal of the work included in this contract, the Contractor shall be deemed to have made such examination, and is therefore familiar with the Innovative Electronics Designs (IED) 500ACS Announcement Control System (ACS), which includes the Flight Announcement System (FAS), the Courtesy Announcement System (CAS), the Security Checkpoint System (SCS), and the Visual Information System (VIS) at Hilo International Airport.

10.2 CONTRACTOR AND PERSONNEL QUALIFICATIONS, AND AVAILABILITY

A. Contractor Qualifications - Contractor shall have a minimum of three (3) consecutive year's experience, immediately prior to the bid opening date, in the field of electronic equipment maintenance service.

At the time of bidding, the Contractor is required to have a valid State of Hawaii "C-13" Electrical License and/or "C-15" Electronic Systems Contractor license, and factory certified and authorized by IED to provide service and maintenance for IED 500ACS.

B. Personnel Qualifications

1. Personnel assigned to this contract shall be:

a. Experienced electronic technicians with a minimum of two (2) years or 60 credit hours of formal academic training in analog and digital electronic theory;

b. Two (2) years of work experience in electronic maintenance in any of the specific fields listed in Section 10.2 A above; and

2. All prospective bidders must be able to produce documented training/certification and maintenance experience to substantiate their claims as indicated in Sections 10.2 A and 10.2 B.1 above.

## SECTION 1 - DEFINITION AND TERMS

Whenever the following pronouns are used in these specifications, or in any documents or instruments where these specifications govern, the intent and meaning shall be interpreted as follows:

1.1 ADDENDA - A written document which may be issued by the Director during the bidding period involving changes to the specifications and plans, if any, which shall be considered and made a part of the contract.

1.2 AIRPORTS DIVISION - Airports Division, Department of Transportation, State of Hawaii.

1.3 AWARD - The written acceptance of a proposal by the State.

1.4 BIDDER - Any individual, partnership, corporation or other legal entity, or combination thereof, submitting a proposal for the work contemplated, acting either directly or through a duly authorized representative.

1.5 CALENDAR DAY - Every day shown on the calendar. If no designation of calendar or working day is made, "day" shall mean calendar day.

1.6 CHANGE ORDER - A written order issued by the Director to the Contractor requiring the contract work to be performed in accordance with a change or changes that may involve an adjustment in contract time and price or requiring performance of any unforeseen work essential to complete the contract.

1.7 CONTRACT - The written agreement between the State and the Contractor setting forth the obligations of the parties thereunder, including, but not limited to, the performance of the work, the furnishing of labor and materials, and the basis of payment.

The contract includes the (1) notice to bidders, (2) proposal, (3) contract form and contract bond, (4) specifications, (5) special provisions and plans, if any, (6) addenda, (7) notice to proceed, and (8) change orders and agreements that are required to complete the work, all of which constitute one instrument.

1.8 CONTRACT BOND - The approved form of security, executed by the Contractor and its Surety or Sureties, guaranteeing the completion of the work in accordance with the terms of the contract, and guaranteeing full payment of all claims for labor, materials, and supplies used or incorporated in the work.

1.9 CONTRACT TIME - The number of working days or calendar days allowed for completion of the contract, including authorized time extensions.

If a calendar date is specified as the date of completion in lieu of the number of working days or calendar days, the contract shall be completed by that date.

In case the contract is for a specified period of time, the contract time shall be for said specified period of time.

1.10 CONTRACTOR - The individual, partnership, corporation or other legal entity, or combination thereof, contracting with the State for performance of the prescribed work.

1.11 DEPARTMENT - The State Department of Transportation.

1.12 DIRECTOR - The Director of Transportation, acting either directly or through the Director's duly authorized representative.

1.13 EQUAL OR APPROVED EQUAL - Whenever this term is used in the specifications and plans, if any, it means a brand or article pre-qualified in accordance with Section 6.2 Trade Names and Alternates and which may be used in place of the one specified.

1.14 H.A.R. or HAR - Hawaii Administrative Rules.

1.15 H.R.S. or HRS - Hawaii Revised Statutes.

1.16 HARBORS DIVISION - Harbors Division, Department of Transportation, State of Hawaii.

1.17 HIGHWAYS DIVISION - Highways Division, Department of Transportation, State of Hawaii.

1.18 HOLIDAYS - The days which are set apart and established as State holidays pursuant to Section 8-1, H.R.S.

1.19 INSPECTOR - The Director's authorized representative assigned to make detailed inspections of contract performance and materials supplied.

1.20 NOTICE TO BIDDERS - The public announcement, as required by law, inviting proposals for the work to be performed or materials to be furnished.

1.21 NOTICE OF FINAL ACCEPTANCE - Written notice from the Director to the Contractor that the entire contract has been completed in all respects in accordance with the specifications and plans, if any, and any changes thereof previously approved by the Director.

1.22 NOTICE TO PROCEED - Written notice from the Director to the Contractor advising the Contractor of the date on which he is to begin the prosecution of the work.

1.23 PLANS - The contract drawings approved by the Director which show the location, character, dimensions and details of the work to be done and shall be a part of the contract.

1.24 PROCUREMENT OFFICER - The Director's duly authorized representative including project managers, project engineers and contract administrators assigned to prepare, evaluate and administer contracts for the purchasing of goods and services.

1.25 PROPOSAL (OR BID) - The offer of a bidder, on the prescribed form, to perform the work and to furnish the labor and materials at the prices quoted.

1.26 PROPOSAL FORM - The approved format prepared by the Department or a facsimile thereof on which bids for the work must be prepared and submitted. (Reasonable facsimile acceptable for bidding.)

1.27 PROPOSAL GUARANTY - The security furnished with a proposal to guarantee that the bidder will enter into the contract and furnish all other requirements if the bidder's proposal is accepted.

1.28 QUALIFICATION QUESTIONNAIRE - The specified forms on which the bidder shall furnish required information as to the bidder's ability to perform and finance the work.

1.29 S.L.H. or SLH - Session Laws of Hawaii.

1.30 SPECIAL PROVISIONS - Revisions to the specifications. The specific clauses setting forth conditions or requirements peculiar to the project under consideration which are not thoroughly or satisfactorily stipulated in these specifications.

1.31 SPECIFICATIONS - The directions, provisions, and requirements pertaining to the method and manner of performing the work and to the quantities and qualities of materials to be furnished under the contract.

1.32 STATE - The State of Hawaii.

1.33 SUBCONTRACTOR - An individual, partnership, corporation, other legal entity, or any combination thereof, that enters into an agreement with the Contractor to perform a portion of the work for the Contractor.

1.34 SUPERINTENDENT - The Contractor's representative who is responsible for and in charge of the work.

1.35 SURETY - The corporation, partnership or individual, other than the Contractor, executing a bond furnished by the Contractor and guaranteeing performance by the Contractor.

1.36 TITLES (OR HEADINGS) - The titles or headings of the Sections herein are intended for convenience of reference and shall not be considered as having any bearing on their interpretation. Unless otherwise indicated, whenever the word "Section" is used, reference is being made to a Section in these specifications.

1.37 WORK - The furnishing of all labor, materials, equipment, and other incidentals necessary or convenient for the successful completion of the project and the execution of all the duties and obligations imposed by the contract.

1.38 WORKING DAY - Any day, except Saturdays, Sundays and State holidays.

## SECTION 2 - PROPOSAL REQUIREMENTS AND CONDITIONS

2.1 QUALIFICATION OF BIDDERS - Prospective bidders must be capable of performing the work for which bids are called.

In accordance with Section 103D-310, HRS, the Department may require any prospective bidder to submit answers to questions contained in the "Standard Qualification Questionnaire for Prospective Bidders on Public Works Contracts" on the form furnished by the Department, properly executed and notarized, setting forth a complete statement of the experience of such prospective bidder and its organization in performing similar work and a statement of the equipment proposed to be used, together with adequate proof of the availability of such equipment. Whenever it appears to the Department, from answers to the questionnaire or otherwise, that the prospective bidder is not fully qualified and able to perform the intended work, the Department will, after affording the prospective bidder an opportunity to be heard and if still of the opinion that the bidder is not fully qualified to perform the work, refuse to receive or consider any bid offered by the prospective bidder. All information contained in the answers to the questionnaire shall be kept confidential. Questionnaire so submitted shall be returned to the bidders after serving their purpose.

Failure to complete the qualification questionnaire will be sufficient cause for the Department to disqualify a prospective bidder.

No person, firm or corporation may bid where (1) the person, firm, or corporation, or (2) a corporation owned substantially by the person, firm, or corporation, or (3) a substantial stockholder or an officer of the corporation, or (4) a partner or substantial investor in the firm is in arrears in payments owed to the State of Hawaii or its political subdivisions or is in default as a surety or failure to do faithfully and diligently previous contracts with the State.

2.2 REJECTION OF PROPOSALS CONTAINING ALTERATIONS, ERASURES, OR IRREGULARITIES - Proposals may be rejected if they show any alterations of form, additions not called for, conditional bids, incomplete bids, erasures, or irregularities of any kind.

When proposals are signed by any agent, other than the officer or officers of a corporation authorized to sign contract on its behalf or a member of copartnership, a Power of Attorney must be on file with the Department prior to opening bids or shall be submitted with the proposal; otherwise, the proposal may be rejected as irregular and unauthorized.

Members of a joint venture may be requested to supply the Department with a copy of their joint venture agreement or each member of the joint venture may be required to sign the proposal.

2.3 PROPOSAL GUARANTY - A proposal guaranty (bid bond) is not required except when specifically noted in the proposal section of the bid document.

When a proposal guaranty is required with a bid, it will be specifically stated in the proposal; and no proposal totaling \$25,000 or more will be considered unless accompanied by one of the following forms of bidder's security:

- A. a deposit of legal tender; or
- B. a surety bid bond underwritten by a company licensed to issue bonds in the State of Hawaii and submitted on the standard form provided herewith; or
- C. a certificate of deposit, share certificate, cashier's check, treasurer's check, teller's check, or official check drawn by, or a certified check accepted by and payable on demand to the State by a bank, savings institution, or credit union insured by the Federal Deposit Insurance Corporation (FDIC) or the National Credit Union Administration (NCUA).
  - 1. The bidder may use these instruments only to a maximum of one hundred thousand dollars (\$100,000.00).
  - 2. If the required security or bond amount totals over one hundred thousand dollars (\$100,000.00), more than one instrument not exceeding one hundred thousand dollars (\$100,000.00) each and issued by different financial institutions shall be acceptable.
  - 3. The instrument shall be made payable at sight to the Department of Transportation, State of Hawaii.

According to Section 103D-323, HRS, the above shall be in a sum not less than five percent (5%) of the amount bid.

2.4 DELIVERY OF PROPOSALS - Each proposal shall be placed, together with the proposal guaranty when required, in an envelope and sealed and so marked as to indicate the identity of the project, the name and address of the bidder, and other required information and then delivered as indicated in the Notice to Bidders. Proposals will be received up to the time fixed in the Notice to Bidders for the opening of bids.

2.5 WITHDRAWAL OF PROPOSALS - Any proposal may be withdrawn at any time prior to the time fixed in the Notice to Bidders for the opening of proposals upon the filing of a written request therefore with the Department, executed by the bidder or a duly authorized representative. The withdrawal of a proposal shall not preclude a bidder from submitting a new proposal.

2.6 PUBLIC OPENING OF PROPOSALS - Proposals will be opened and read publicly at the time and place indicated in the Notice to Bidders. Bidders or their authorized agents are invited to be present.

2.7 DISQUALIFICATION OF BIDDERS - Any of the following reasons may be considered as being sufficient grounds for the disqualification of a bidder and the rejection of his proposal or proposals.

A. More than one proposal for the same work from an individual, firm, or corporation under the same or different name.

B. Evidence of collusion among bidders. Participants in such collusion will receive no recognition as bidders for any future work of the Department until such participant shall have been reinstated as a qualified bidder.

C. Evidence of assistance from a person who has been an employee of the agency within the preceding two years and who participated while in State office or employment in the matter with which the contract is directly concerned, pursuant to Section 84-15, H.R.S.

D. Lack of proposal guaranty.

E. Unsigned proposal or proposal not signed in ink by person or persons legally authorized to submit a proposal on behalf of the bidder.

2.8 MATERIAL GUARANTY - The bidder may be required to furnish a complete statement of the origin, composition and manufacture of any or all materials to be used in the prosecution of the work, together with samples. Such samples may be subjected to tests to determine their quality and fitness for the work.

SECTION 3 - AWARD AND EXECUTION OF CONTRACT

3.1 AWARD OF CONTRACT - The State reserves the right to reject any and all proposals and to waive any defects as may be deemed to be in the best interest of the public.

The award of contract, if it be awarded, will be made within sixty (60) calendar days after the opening of bids to the lowest responsive and responsible bidder whose proposal complies with all the prescribed requirements. The successful bidder will be notified, by letter mailed to the address shown in its proposal, that its proposal has been accepted and it has been awarded the contract.

**Requirement for award.** To be eligible for award, the apparent low Bidder will be contacted to submit copies of the documents listed below to demonstrate compliance with Section 103D-310(c), HRS. The documents should be submitted to the Department as soon as possible. If a valid certificate/clearance is not submitted on a timely basis for award of a contract, a Bidder otherwise responsive and responsible may not receive the award.

**A. Tax Clearance.**

Pursuant to §103D-310(c), 103-53 and 103D-328, HRS, the successful bidder shall be required to submit a certified copy of its tax clearance issued by the Hawaii State Department of Taxation (DOTAX) and the Internal Revenue Service (IRS) to demonstrate its compliance with Chapter 237, HRS. A tax clearance is valid for six (6) months from the most recent approval stamp date on the tax clearance and must be valid on the bid's first legal advertisement date or any date thereafter up to the bid opening date.

FORM A6, TAX CLEARANCE CERTIFICATE, is available at the following website:

<http://www.hawaii.gov/tax/>

To receive DOTAX Forms by fax or mail, phone (808)587-7572 or 1-800-222-7572.

The application for the Tax Clearance Certificate is the responsibility of the bidder, and must be submitted directly to the DOTAX or IRS. The approved certificate may then be submitted to the Department.

**B. DLIR Certificate of Compliance.**

Pursuant to §103D-310(c), HRS, the successful bidder shall be required to submit a copy (faxed copies are acceptable) of its approved Certificate of Compliance issued by the Hawaii State Department of Labor and Industrial Relations (DLIR) to demonstrate its compliance with unemployment insurance (Chapter 383, HRS), workers' compensation (Chapter 386, HRS), temporary disability insurance (Chapter 392, HRS), and prepaid health care (Chapter 393, HRS). The certificate is valid for six (6) months from the most recent approval stamp date on the certificate and must be valid on the bid's first legal advertisement date or any date thereafter up to the bid opening date. For certificates which receive a "pending" approval stamp, a DLIR approval stamp is required prior to the issuance of the Notice to Proceed.

FORM LIR#27, APPLICATION FOR CERTIFICATE OF COMPLIANCE WITH SECTION 3-122-112, HAR, is available at the following website:

[www.hawaii.gov/labor](http://www.hawaii.gov/labor)

More information is available by calling the DLIR Unemployment Insurance Division at (808) 586-8926.

Inquiries regarding the status of a LIR#27 Form may be made by calling the DLIR Disability Compensation Division at (808)586-9200.

The application for the Certificate of Compliance is the responsibility of the bidder, and must be submitted directly to the DLIR. The approved certificate may then be submitted to the Department.

**C. DCCA Certificate of Good Standing.**

Pursuant to §103D-310(c), HRS, the successful bidder shall be required to submit a copy (faxed copies are acceptable) of its approved Certificate of Good Standing issued by the Hawaii State Department of Commerce and Consumer Affairs (DCCA), Business Registration Division (BREG) to demonstrate that it is either:

- (1) incorporated or organized under the laws of the State; or
- (2) registered to do business in the State as

a separate branch or division that is capable of fully performing under the contract.

A Certificate of Good Standing is valid for six (6) months from the approval date on the certificate and must be valid on the bid's first legal advertisement date or any date thereafter up to the bid opening date. A Hawaii business that is a sole proprietorship, is not required to register with the BREG, and therefore not required to submit a Certificate of Good Standing. Bidders are advised that there are costs associated with registering and obtaining a Certificate of Good Standing from the DCCA.

To purchase a CERTIFICATE OF GOOD STANDING, go to On-Line Services at the following website:

[www.hawaii.gov/dcca/](http://www.hawaii.gov/dcca/)

The application for the Certificate of Good Standing is the responsibility of the bidder, and must be submitted directly to the DCCA. The approved certificate may then be submitted to the Department.

3.2 CANCELLATION OF AWARD - The State reserves the right to cancel the award of any contract any time before the execution of said contract by all parties without any liability to the successful bidder or any other bidder.

3.3 RETURN OF PROPOSAL GUARANTY - All proposal guaranties, except those of the lowest two (2) bidders, will be returned immediately following the opening and checking of the proposals. The retained proposal guaranty of the second lowest bidder, if not a bid bond, will be returned within ten (10) calendar days following execution of contract by the successful bidder. The successful bidder's proposal guaranty, if not a bid bond, will be returned after a satisfactory contract bond has been furnished and the contract has been executed.

3.4 REQUIREMENT OF CONTRACT BOND - Only when required by the proposal, the successful bidder at the time of the execution of the contract shall file good and sufficient performance and payment bonds on the forms furnished by the Department, or a facsimile thereof, conditioned for the full and faithful performance of the contract in accordance with the terms and intent thereof and also for the prompt payment to all others for all labor and materials furnished by them to it and use in the prosecution of the work provided for in such contract,

in the manner, form and amount required by Section 3-122-224(b)(2), H.A.R., which bonds shall be in an amount equal to fifty per cent (50%) of the contract price, including amounts estimated to be required for extra work, or in the case of price-term, open-end, or requirements contract under which the total amount to be paid to the Contractor cannot be accurately estimated at the time the contract is to be awarded, the bond amounts shall be as designated in the bid documents. Such bonds shall also by their terms inure to the benefit of any and all persons entitled to file claims for labor performed or materials furnished in the work so as to give them a right of action as contemplated by Section 103D-324, H.R.S.

The bidder shall limit the acceptable performance and payment bonds to the following:

- (a) Legal tender; or
- (b) Surety bond underwritten by a company licensed to issue bonds in the State of Hawaii; or
- (c) A certificate of deposit; share certificate,; cashier's check; treasurer's check; teller's check drawn by or a certified check accepted by and payable on demand to the State by a bank, savings institution or credit union insured by the Federal Deposit Insurance Corporation (FDIC) or the National Credit Union Administration (NCUA).

1. The bidder may use these instruments only to a maximum of one hundred thousand dollars (\$100,000.00).

2. If the required security or bond amount totals over one hundred thousand dollars (\$100,000.00) more than one instrument not exceeding one hundred thousand dollars (\$100,000.00) each and issued by different financial institutions shall be acceptable.

3.5 EXECUTION OF CONTRACT - The contract and the "Certificate for Performance of Services", similar to a copy of the same annexed hereto, shall be executed by the successful bidder and returned, together with the contract bonds, when required, within ten (10) days after the award of the contract or within such further time as the Director may allow after the bidder has received the contract for execution.

Pursuant to Section 103D-309, H.R.S., the contract shall not bind the State in any way unless said contract has been fully and properly executed by all the parties thereto and

the Comptroller has endorsed thereon a certificate that there is available an unexpended appropriation over and above all outstanding contracts, sufficient to cover the amount required by the contract.

3.6 FAILURE TO EXECUTE CONTRACT - Failure to execute the contract, Certificate for Performance of Services and file acceptable bonds, when required, within ten (10) days after the award of the contract, or within such further time as the Director may allow, shall be cause for the cancellation of the award and the forfeiture of the proposal guaranty. Award of the contract may then be made to the next lowest responsible bidder.

## SECTION 4 - SCOPE OF WORK

4.1 WORK TO BE DONE - The work to be done is described in the Section(s) following Section 9 of these specifications.

4.2 PERFORMANCE OF WORK - The Contractor shall employ, so far as possible, such methods and means in carrying out his work so as not to cause any interruption, disturbance, or interference with the public.

In case the Contractor is performing work in a building, the Contractor shall conduct the work in such a manner so as not to cause any interruption, disturbance, or interference with the business activities of the tenants in the building.

4.3 EXTRA WORK - New and unforeseen items of work will be classed as extra work when they cannot be covered by any of the various items for which there is a bid price.

### 4.4 CHANGES AND CLAIMS FOR ADJUSTMENT

A. Change order. By a written order, at any time, and without notice to any surety, the procurement officer may, subject to all appropriate adjustments, make changes within the general scope of this contract in any one or more of the following:

1. Drawings, designs, or specifications, if the goods to be furnished are to be specially manufactured for the State in accordance therewith;
2. Method of shipment or packing;
3. Place of delivery;
4. Changes in the work within the scope of the contract; or
5. Changes in the time of performance of the contract that do not alter the scope of work.

B. Adjustments of price or time for performance. If any change order increases or decreases the contractor's cost of, or the time required for, performance of any part of the work under this contract, whether or not changed by the order, an adjustment shall be made and the contract modified in writing accordingly. Any adjustment in contract price made pursuant to this clause shall be determined in accordance with the price adjustment clause of this contract. Failure of the parties to agree to an adjustment shall not excuse the contractor from proceeding with the contract as changed, provided that the procurement officer promptly and duly make the provisional adjustments in payment or time for performance as may be reasonable. By proceeding with the work, the contractor shall not be deemed to have

prejudiced any claim for additional compensation, or an extension of time for completion.

C. Time period for claim. Within thirty (30) days after receipt of a written change order under subsection (a) unless the period is extended by the procurement officer in writing, the contractor shall file notice of intent to assert a claim for an adjustment. Later notification shall not bar the contractor's claim unless the State or county is prejudiced by the delay in notification.

D. Claim barred after final payment. No claim by the contractor for an adjustment hereunder shall be allowed if notice is not given prior to final payment under this contract.

E. Other claims not barred. In the absence of a change order, nothing in this clause shall be deemed to restrict the contractor's right to pursue a claim as under the contract or for breach of contract.

#### 4.5 PRICE ADJUSTMENT

Any adjustment in contract price pursuant to a clause in this contract shall be made in one or more of the following ways:

A. By agreement on a fixed price adjustment before commencement of the pertinent performance or as soon thereafter as practicable;

B. By unit prices specified in the contract or subsequently agreed upon;

C. By the costs attributable to the event or situation covered by the clause, plus appropriate profit or fee, all as specified in the contract or subsequently agreed upon;

D. In such other manner as the parties may mutually agree; or

E. In the absence of agreement between the parties, by a unilateral determination by the procurement officer of the costs attributable to the event or situation covered by the clause, plus appropriate profit or fee, all as computed by the procurement officer in accordance with generally accepted accounting principles and applicable sections of chapters 3-123 and 3-126 of the Hawaii Administrative Rules.

#### 4.6 VARIATION IN QUANTITY

Upon agreement of the parties, the quantity of goods or services or both specified in this contract may be increased by a maximum of ten (10) percent provided (1) the unit prices will remain the same except for any price adjustments otherwise applicable and (2) the procurement officer makes a written determination that such an increase will either be more economical than awarding another contract or that it would not be practical to award another contract.

## SECTION 5 - CONTROL OF WORK

5.1 AUTHORITY OF DIRECTOR - The Director shall decide all questions which may arise as to the quality or acceptability of materials furnished and work performed; the manner of performance and rate of progress of the work; the compensation for work performed; the interpretation of the contract and the fulfillment of the contract on the part of the Contractor. The Director's decision shall be final and the Director shall have the authority to enforce any such decision and order which the Contractor fails to carry out promptly and diligently. The Director shall have the following powers in the way of enforcement:

- A. The right to suspend the work.
- B. The right to withhold payment due the Contractor.

5.2 COORDINATION OF PLANS, SPECIFICATIONS AND SPECIAL PROVISIONS - These specifications, the plans, special provisions, and all supplementary documents are essential parts of the contract, and a requirement occurring in one is as binding as though occurring in all. They are intended to describe and provide for the complete work.

5.3 COOPERATION OF CONTRACTOR AND DIRECTOR - The Contractor shall have available at the work site at all times, a copy of the specifications, special provisions and plans. The Contractor shall give the work constant attention to facilitate the progress thereof and shall cooperate with the Director in every way possible.

Before starting work on the project, the Contractor shall designate in writing a superintendent who shall have complete authority to represent and to act for the Contractor.

5.4 INSPECTION - The Director at all times shall have access to the work during its prosecution and shall be furnished with every reasonable facility for ascertaining that the materials and the workmanship are in accordance with the requirements and intentions of these specifications and special provisions. All work done and all materials furnished shall be subject to the Director's inspection and approval.

The inspection of the work shall not relieve the Contractor of any of its obligations to fulfill its contract as prescribed, and defective work shall be made good and unsuitable materials may be rejected, notwithstanding that such defective work and materials may have been previously overlooked by the Director and accepted or included in an estimate for payment.

Projects financed in whole or in part with Federal funds shall be subject to inspection at all times by representatives of the Federal agency involved.

5.5 REMOVAL OF DEFECTIVE AND UNAUTHORIZED WORK - All work which has been rejected shall be corrected or removed and replaced by the Contractor in an acceptable manner and no compensation will be allowed the Contractor for such correction or removal and replacement. Upon failure on the part of the Contractor to comply promptly with any order of the Director, the Director may cause any rejected work to be corrected or removed and replaced and to deduct the costs thereof from any monies due or to become due the Contractor.

5.6 CLAIMS AND DISPUTES - The Contractor may give notice in writing to the Director for claims that extra compensation, damages, or an extension of time for completion is due the Contractor for one or more of the following reasons:

- A. Requirements not clearly covered in the contract, or not ordered by the Director as extra work;
- B. Failure between the State and the Contractor to agree to an adjustment in price for a contract change order issued by the State; or
- C. An action or omission on the part of the Director requiring performance changes within the scope of the contract.

The Contractor shall continue with performance of the contract in compliance with the directions or orders of the procurement officer, but by so doing, the Contractor shall not be deemed to have prejudiced any claim for additional compensation, damages, or an extension of time for completion; provided:

- A. The notice in writing be given:
  - 1. Before the commencement of the work involved, if at that time the Contractor knows of such requirements or the occurrence of such actions or omissions; or
  - 2. Within thirty (30) calendar days after the Contractor knows of such requirements or the occurrence of such action or omission if the Contractor did not have such knowledge before the commencement of the work; or
  - 3. Within thirty (30) calendar days after receipt of the written contract change order that was not

agreed upon by both parties; or

4. Within such further time as may be allowed by the Director in writing.

B. The notice shall clearly state the Contractor's intention to make claim and the reasons why the Contractor believes that additional compensation, changes or an extension of time may be remedies to which the Contractor is entitled; and afford the Director every facility for keeping records of the actual cost of work. Failure on the part of the Contractor to give such notification or to afford the procurement officer proper facilities for keeping strict account of actual cost shall constitute waiver of the claim for such extra compensation. The filing of such notice by the Contractor and the keeping of costs by the procurement officer shall not in any way be construed to prove the validity of the claim.

The Director will review the notice and render a decision. The Director's decision shall be final and conclusive unless, within thirty (30) calendar days from the date of the decision, the Contractor mails or otherwise furnishes a written appeal to the Director. The decision of the Director shall be final. Later notification of such claims shall not bar the Contractor's claim unless the State is prejudiced by the delay in notification. No claim by the Contractor for an adjustment hereunder shall be allowed if notice is not given before final payment under this contract.

Any adjustment in the contract price made pursuant to this clause shall be determined according to Section 4.5 - Price Adjustment.

The provisions of this Section shall not be construed as establishing any claims contrary to the terms of Section 4.4 - Changes and Claims for Adjustment.

Nothing herein contained, however, shall excuse the Contractor from compliance with any rules of law precluding any state officers and any Contractors from acting in collusion or bad faith in issuing or performing contract change orders which are clearly not within the scope of the contract.

SECTION 6 - CONTROL OF MATERIAL AND EQUIPMENT

6.1 DEFECTIVE MATERIALS - All materials not conforming to the requirements of these specifications or the special provisions shall be considered defective and all such materials, whether in place or not, shall be rejected. They shall be removed immediately from the site of the work, unless otherwise permitted by the Director. No rejected materials, the defects of which have been subsequently corrected, shall be used until approval in writing has been given by the Director. Upon failure on the part of the Contractor to comply promptly with any order to remove and replace defective materials, the Director may remove and replace defective material and to deduct the cost of removal and replacement from any monies due or to become due the Contractor.

6.2 TRADE NAMES AND ALTERNATES - For convenience in designation on the plans or in the specifications, certain equipment or articles or materials may be designated under a trade name or the name of a manufacturer and its information catalogue. The use of alternate equipment or an article or material which is of equal quality and of the required characteristics for the purposes intended will be permitted, subject to the written approval of the Director, in accordance with the following requirements:

A. QUALIFICATION BEFORE BID OPENING - When the specifications and/or plans specify one or more manufacturer's brand names of materials or equipment to indicate a quality, style, appearance, or performance, the bidder will be assumed to have based its bid on one of the specified named products, except where such proprietary product are specified, alternate brands may be qualified if found equal or better by the Director. Bidders requesting qualification of alternate proprietary products must submit a request to the Director for review and approval at the earliest date possible, but in any event, such request must be received at the Contracts office not later than ten (10) days before the bid opening date, not including the bid opening date.

It shall be the responsibility of the bidder to submit sufficient evidence based upon which a determination can be made by the Director that the alternate brand is qualified. The evidence shall be transmitted with a covering letter which shall list the evidence submitted and the items for which the substitution is requested.

If the evidence accompanying a request for substitution is insufficient to qualify a particular

model, the request shall be denied provided that further evidence may be submitted to qualify the item five (5) days prior to the bid opening date if the initial request was made prior to the deadline set above.

B. SUBSTITUTION AFTER BID OPENING - Substitution of material or equipment will not be allowed after the bid opening date except under the following unforeseen circumstances:

1. If a specified or pre qualified item is delayed by a lengthy strike in the factory or other unforeseeable contingency beyond the control of the Contractor which would cause an abnormal delay in the project completion.
2. If a specified or pre qualified item is found to be unusable due to change or other circumstances.
3. If the Contractor is willing to provide a more recently developed or manufactured item of material or equipment of the same manufacturer which the Director determines to be equal or better than the one specified or pre-qualified.

A substitution request, regardless of reason, shall be fully explained in writing by the Contractor and shall include its justification for said request, the quantities and unit prices involved, quotations and such other documents as are deemed necessary to support the request. Any savings in cost will accrue to the State and any additional cost for the substituted items will be paid by the Contractor.

The burden of proof as to the comparative quality and suitability of alternate equipment, articles, or materials shall be upon the bidder or Contractor and bidder or Contractor shall furnish, at its own expense, all information necessary or related thereto as required by the Director. The Director shall be the sole judge as to the comparative quality and suitability of alternate equipment, articles or materials and the Director's decisions shall be final.

The above shall not be construed to mean that substitution for brand name specified materials and equipment will be allowed; the Director reserves the right to deny any request he deems irregular or not in the best interest of the State.

6.3 ASSIGNMENT OF ANTITRUST CLAIMS FOR OVERCHARGES FOR GOODS AND MATERIALS PURCHASED

A. Vendor and purchaser recognize that in actual economic practice, overcharges resulting from antitrust violations are in fact usually borne by the purchaser. Therefore, vendor hereby assigns to purchaser any and all claims for such overcharges as to goods and materials purchased in connection with this order or contract, except as to overcharges which result from antitrust violations commencing after the price is established under this order or contract and which are not passed on to the purchaser under an escalation clause.

B. Contractor and owner recognize that in actual economic practice, overcharges resulting from antitrust violations are in fact usually borne by the owner. Therefore, contractor hereby assigns to owner any and all claims for such overcharges as to goods and materials purchased in connection with this order or contract, except as to overcharges which result from antitrust violations commencing after the price is established under this order or contract and any change order. In addition, contractor warrants and represents that each of its first tier suppliers and subcontractors shall assign any and all such claims to owner, subject to the aforementioned exception.

SECTION 7 - LEGAL RELATIONS AND RESPONSIBILITY

7.1 LAWS TO BE OBSERVED - The Contractor shall comply with all federal, state, city and county laws, ordinances, rules and regulations which in any manner affect those engaged or employed in the work, the materials used in the work, and the conduct of the work. Any reference to such laws, ordinances, rules and regulations shall include any amendments thereto effective as of the date of the call for sealed proposals.

The Contractor shall hold harmless, indemnify, defend and where appropriate, insure the State, its officers, agents and employees against any claim or liability arising from or based on the violation of any such laws, ordinances, rules or regulations. If any discrepancy or inconsistency is discovered in the contract for the work in relation to any law, ordinance, rule, regulation, order or decree, the Contractor shall forthwith report the same to the Director in writing.

7.2 PERMITS AND LICENSES - The Contractor shall procure all permits and licenses, pay all charges and fees, and give all notices necessary and incident to the due and lawful prosecution of the work.

7.3 PATENTS - The Contractor shall assume all costs arising from the use of patented materials, equipment, devices, or processes used on or incorporated in the work, and shall hold harmless, indemnify, defend and where appropriate, insure the State, its officers, agents and employees from all suits at law or actions of every nature, for or on account of the use of any patented materials, equipment, devices or processes.

7.4 RESPONSIBILITY FOR INJURY AND DAMAGE - The State, its officers, agents and employees shall not be held accountable in any manner for any loss or damage to the work or any part thereof, or for any of the materials and equipment used or employed in performing the work, or for any injury to any person or persons either workers or the public, or for any damage to property caused by the Contractor or its workers or any one employed by the Contractor. The Contractor shall be responsible for any liability imposed by law for any injury to any person or any damage to property resulting from defects or obstructions or from any cause whatsoever during the progress of the work or at any time before its completion and final acceptance. The acceptance of the completed work of the Contractor by the Director shall not relieve the Contractor from any liability which may have accrued or may accrue as a result of the performance of the work by the Contractor. The Contractor shall hold harmless, indemnify, defend and where appropriate, insure the State, its officers, agents and employees, from all suits or actions of every name, kind and description, brought for or on account of

any injuries or damages sustained by any persons or property caused by the Contractor, its servants or agents, or by or on account of any act or omission of the Contractor or its servants or agents, regardless of whether such actions or any claim is brought against them or any one of them before or after the final acceptance of the work. In addition to any remedy authorized by law, the State may withhold payment of any money due to Contractor as shall be reasonable until disposition has been made of any suits or claims for injuries or damages.

It is not the intention of the parties to this contract to make the public or any member thereof a third party beneficiary hereunder, or to authorize anyone not a party hereto to maintain a suit for personal injuries or property damage based on a contract theory of liability. In any event, the Contractor shall hold harmless, indemnify, defend and where appropriate, insure the State from suits and claims for personal injuries or property damage where such injuries or damage are caused by the negligent acts or omissions of the Contractor, its agents or employees.

7.5 COOPERATION BETWEEN CONTRACTORS - Where two or more Contractors are employed on related or adjacent work, each shall conduct its operations in such a manner as not to cause any unnecessary delay or hindrance to the other.

7.6 CONTRACTOR'S RESPONSIBILITY FOR WORK - Until the acceptance of the contract, the Contractor shall have the charge and care thereof and shall bear the risk of injury or damage to any part thereof by the action of the elements or from any other cause, whether arising from the execution or from the non-execution of the work. The Contractor shall rebuild, repair, restore, and make good all damages to any portion of the work occasioned by any of the above causes before its completion and acceptance and shall bear the expenses thereof.

7.7 NO PERSONAL LIABILITY - Neither the Director nor any other officer or authorized employee of the Department shall be personally responsible for any liability arising under the contract.

7.8 LABOR AND COMPENSATION REQUIREMENTS - Wages paid each laborer employed by the Contractor or any subcontractor shall not be less than the prevailing minimum wage rate prescribed by law.

Every laborer employed by the Contractor or any subcontractor whose rate of compensation is Five Dollars (\$5.00) or less per day shall be paid his wages weekly pursuant to Section 103-54, H.R.S.

The Contractor's attention is directed to Chapter 377, H.R.S., Hawaii Employment Relations Act; Chapter 378, H.R.S., Employment Practices; Chapter 383, H.R.S., Hawaii Employment Security Law; Chapter 386, H.R.S., Workers' Compensation Law; Chapter 387, H.R.S., Wage and Hour Law; Chapter 392, H.R.S., Temporary Disability Insurance; Chapter 393, H.R.S., Prepared Health Care Act; Chapter 396, H.R.S., Occupational Safety and Health; and Section 103-55, H.R.S., Wages, Hours, Working Conditions of Employees of Contractor's Supplying Services.

7.9 INSURANCE - Prior to commencing with the work, the Contractor shall, at its own expense, obtain and submit to the Department, Certificate of Insurance from an insurance company authorized by the laws of the State to issue such insurance in the State of Hawaii showing full policy coverage of the Contractor.

TYPES OF INSURANCE:

A. Workers' Compensation:

The Contractor shall obtain worker's compensation insurance for all persons whom they employ in carrying out the work under this contract. This insurance shall be in strict conformity with the requirements of the most current and applicable State of Hawaii Worker's Compensation Insurance laws in effect on the date of the execution of this contract and as modified during the duration of the contract. The minimum limit of liability for workers compensation is the HRS 386 statutory limit.

B. Comprehensive Automobile Liability:

The Contractor shall obtain Auto Liability Insurance covering all owned, non-owned and hired autos with a combined single Limit of not less than \$1,000,000 per accident for bodily injury and property damage with the State of Hawaii named as additional insured. The required limit of insurance may be provided by a single policy or with a combination of primary and excess

policies.

C. Commercial General Liability:

The Contractor shall obtain General Liability insurance with a limit of not less than \$1,000,000 per occurrence and in the aggregates. The General liability insurance shall include the State of Hawaii as an additional insured. The required limit of insurance may be provided by a single policy or with a combination of primary and excess policies.

All policies must provide that 30 days prior written notice of cancellation or material change in coverage be given to certificate holders stated above.

Such insurance when accepted by the Director in writing shall become applicable and shall remain unmodified throughout the entire term of the contract and in no event shall be terminated or otherwise allowed to lapse prior to written certification of final acceptance of the work by the State. Such insurance aforementioned shall cover the State for all work performed under the contract, all work performed incidental thereto or directly or indirectly connected therewith, including other work performed outside of the work area, and all change orders.

Any delay in the submission and approval of insurance certificates shall not be justification of or grounds for a request by the Contractor postponing the issuance of a notice to proceed notwithstanding the fact that the Contractor shall not be allowed to proceed with the work until said certificates are submitted and approved.

Failure to obtain insurance in accordance with the Section, on the part of the Contractor, shall be considered a major breach of the contract; and should the State be forced to expend funds which would have been covered under the insurance, the Contractor agrees to assume the liability for such funds and to indemnify and hold the State harmless.

## SECTION 8 - PROSECUTION AND PROGRESS

8.1 NOTICE TO PROCEED - A "Notice to Proceed" letter will be written to the Contractor by the Director. Such letter will indicate the date the Contractor is to begin work and from which date the contract time will commence to run.

The Contractor shall diligently perform the required duties during the term of the contract, or if the work is to be completed within a specified time limit, the Contractor shall diligently prosecute the work to completion within the specified time limit.

8.2 SUBCONTRACTING - The Contractor shall give its personal attention to the fulfillment of the contract and shall keep the work under its control.

Subject to Section 103D-302, H.R.S., the Contractor may subcontract a portion of the work pursuant to the provisions of this section, but the Contractor shall be primarily responsible for the work so subcontracted. The Contractor shall not subcontract any work to any subcontractor who has been suspended by the State.

Before any work is started under a subcontract, the Contractor shall have the written approval of the Director on a written statement on forms furnished by the Department, indicating the work to be subcontracted, the names of the subcontractors and the description of each portion of the work to be so subcontracted and showing that the subcontractors are particularly experienced and equipped to do the work subcontracted. The Contractor shall give assurance that the minimum wage rate schedule as stated in the contract shall apply to labor performed on the work so subcontracted. Consent of the Director to the subcontracting of work shall not be construed to relieve the Contractor of any responsibility for the fulfillment of the contract.

When any portion of the work which has been subcontracted by the Contractor is not prosecuted in a manner satisfactory to the Director, the Contractor, upon receipt of a notice thereof in writing from the Director, shall remove the subcontractor immediately from the project and the subcontractor shall not again be employed on the work.

8.3 ASSIGNMENT OF CONTRACT - The performance of the contract may be assigned only with the prior written consent of the Director and when applicable, the Contractor's surety. Consent to any assignment shall not relieve the Contractor or the Contractor's surety of any obligations of the contract.

8.4 INSUBORDINATION - If any subcontractor or person employed by the Contractor shall fail or refuse to carry out the directions of the Director or shall appear to the Director to be incompetent or to act in a disorderly or improper manner, the subcontractor or person shall be removed immediately upon request by the Director and shall not again be employed on the work, nor shall it be employed upon any other Department project currently under contract to the same Contractor or subcontractor.

8.5 TEMPORARY SUSPENSION OF WORK

A. Order to stop work. The Director, may, by written order to the contractor, at any time, and without notice to any surety, require the contractor to stop all or any part of the work called for by this contract. This order shall be for a specified period not exceeding sixty (60) days after the order is delivered to the contractor, unless the parties agree to any further period. Any such order shall be identified specifically as a stop work order issued pursuant to this section. Upon receipt of such an order, the contractor shall forthwith comply with its terms and take all reasonable steps to minimize the occurrence of costs allocable to the work covered by the order during the period of work stoppage. Before the stop work order expires, or within any further period to which the parties shall have agreed, the Director shall either:

1. Cancel the stop work order; or
2. Terminate the work covered by such order as provided in the "termination for default clause" or the "termination for convenience clause" of this contract.

B. Cancellation or expiration of the order. If a stop work order issued under this section is canceled or if the period of the order or any extension thereof expires, the contractor shall have the right to resume work. An appropriate adjustment shall be made in the delivery schedule or contract price, or both, and the contract shall be modified in writing accordingly; if:

1. The stop work order results in an increase in the time required for, or in the contractor's cost properly allocable to, the performance of any part of this contract; and
2. The contractor asserts a claim for such an adjustment within thirty (30) days after the end of the period of work stoppage; provided that, if the Director decides that the facts justify such

action, any such claim asserted may be received and acted upon at any time prior to final payment under this contract.

C. Termination of stopped work. If a stop work order is not canceled and the work covered by such order is terminated for default or convenience, the reasonable costs resulting from the stop work order shall be allowable by adjustment or otherwise.

D. Adjustment of price. Any adjustment in contract price made pursuant to this clause shall be determined in accordance with the price adjustment clause of this contract.

8.6 LIQUIDATED DAMAGES - It is mutually understood and agreed by and between the parties to the contract that the performance by the Contractor of its duties every calendar/working day is an essential part of the contract and in case of failure on the part of the Contractor to perform its duties for the time specified in the contract, the State will be damaged thereby and the amounts of said damages being difficult, if not impossible of definite ascertainment and proof, shall be estimated, agreed upon and fixed at the sum shown in the proposal for each and every calendar/working day that the Contractor fails to perform its duties during the period the contract is in effect; and the Contractor shall pay the liquidated damages as provided for in the proposal and, in case the same are not paid, the Department may deduct the amount thereof from any monies due or that may become due the Contractor under the contract.

#### 8.7 DEFAULT AND TERMINATION OF CONTRACT

A. Termination by Default. If the contractor refuses or fails to perform any of the provisions of this contract with such diligence as will ensure its completion within the time specified in this contract, or any extension thereof, otherwise fails to timely satisfy the contract provisions, or commits any other substantial breach of this contract, the Director may notify the contractor in writing of the delay or non-performance and if not cured in ten (10) days or any longer time specified in writing by the Director, such officer may terminate the contractor's right to proceed with the contract or such part of the contract as to which there has been delay or a failure to properly perform. In the event of termination in whole or in part the Director may procure similar goods or services in the manner and upon terms deemed appropriate by the Director. The contractor shall continue performance of the contract to the extent it is not terminated and shall be liable for excess costs incurred in procuring

similar goods or services.

1. Contractor's duties. Notwithstanding termination of the contract and subject to any directions from the Director, the contractor shall take timely, reasonable, and necessary action to protect and preserve property in the possession of the contractor in which the State or county has an interest.

2. Compensation. Payment for completed goods delivered and accepted by the State shall be at the contract price. Payment for the protection and preservation of property shall be in an amount agreed upon by the contractor and Director; if the parties fail to agree, the Director shall set an amount subject to the contractor's rights under chapter 3-126, HAR. The State may withhold from amounts due the contractor such sums as the Director deems to be necessary to protect the State against loss because of outstanding liens or claims of former lien holders and to reimburse the State for the excess costs incurred in procuring similar goods and services.

3. Excuse for nonperformance or delayed performance. Except with respect to defaults of subcontractors, the contractor shall not be in default by reason of any failure in performance of this contract in accordance with its terms, including any failure by the contractor to make progress in the prosecution of the work hereunder which endangers such performance, if the contractor has notified the Director within fifteen (15) days after the cause of the delay and the failure arises out of causes such as: acts of God; acts of the public enemy; acts of the State and any other governmental body in its sovereign or contractual capacity; fires; floods; epidemics; quarantine restrictions; strikes or other labor disputes; freight embargoes; or unusually severe weather. If the failure to perform is caused by the failure of a subcontractor to perform or to make progress, and if such failure arises out of causes similar to those set forth above, the contractor shall not be deemed to be in default, unless the goods or services to be furnished by the subcontractor were unreasonably obtained from other sources in sufficient time to permit the contractor to meet the contract requirements. Upon request of the contractor, the Director shall ascertain the facts and extent of such failure, and if such officer determines that any failure to perform was

occasioned by any one or more of the excusable causes, and that, but for the excusable cause, the contractor's progress and performance would have met the terms of the contract, the delivery schedule shall be revised accordingly, subject to the rights of the State under the clause entitled "Termination for Convenience". As used in this paragraph of this clause, the term "subcontractor" means subcontractor at any tier.

4. Erroneous termination for default. If, after notice of termination of the contractor's right to proceed under the provisions of this clause, it is determined for any reason that the contractor was not in default under the provisions of the clause, or that the delay was excusable under the provisions of paragraph 3 above, Excuse for nonperformance or delayed performance of this clause, the rights and obligations of the parties shall, if the contract contains a clause providing for termination for convenience of the State, be the same as if the notice of termination had been issued pursuant to such clause.

5. Additional rights and remedies. The rights and remedies provided in this clause are in addition to any other rights and remedies provided by law or under this contract.

B. Termination for convenience. The Director may, when the interests of the State so require, terminate this contract in whole or in part, for the convenience of the State. The Director shall give written notice of the termination to the contractor specifying the part of the contract terminated and when termination becomes effective.

1. Contractor's obligation. The contractor shall incur no further obligations in connection with the terminated work and on the dates set in the notice of termination the contractor will stop work to the extent specified. The contractor shall also terminate outstanding orders and subcontracts as they relate to the terminated work. The contractor shall settle the liabilities and claims arising out of the termination of subcontracts and orders connected with the terminated work. The Director may direct the contractor to assign the contractor's right, title, and interest under terminated orders or subcontracts to the State. The contractor must still complete the work not terminated by the notice of termination and may incur obligations as are necessary to do so.

2. Right to goods. The Director may require the contractor to transfer title and deliver to the State in the manner and to the extent directed by the Director:

- a. Any completed goods; and
- b. The partially completed goods and materials, parts, tools, dies, jigs, fixtures, plans, drawings, information, and contract rights hereinafter called "manufacturing material," as the contractor has specifically produced or specially acquired for the performance of the terminated part of this contract.

The Contractor shall, upon direction of the Director, protect and preserve property in the possession of the contractor in which the State has an interest. If the Director does not exercise this right, the contractor shall use the Contractor's best efforts to sell such goods and manufacturing materials. Use of this section in no way implies that the State has breached the contract by exercise of the termination for convenience clause.

3. Compensation:

- a. The Contractor shall submit a termination claim specifying the amounts due because of the termination for convenience together with cost or pricing data to the extent required by subchapter 15, chapter 3-122, HAR, bearing on such claim. If the Contractor fails to file a termination claim within one (1) year from the effective date of termination, the Director may pay the Contractor, if at all, an amount set in accordance with subparagraph c. below.
- b. The Director and the Contractor may agree to settlement provided the Contractor has filed a termination claim supported by cost or pricing data to the extent required by subchapter 15, chapter 3-122, HAR, and that the settlement does not exceed the total contract price plus settlement costs reduced by payments previously made by the State, the proceeds of any sales of goods and manufacturing materials under paragraph (2) of this clause, and the contract price of the work not terminated.

c. Absent complete agreement under subparagraph b above, the Director shall pay the Contractor the following amounts, provided payments agreed to under subparagraph b shall not duplicate payments under this subparagraph for the following:

(i) Contract prices for goods or services accepted under the contract;

(ii) Costs incurred in preparing to perform and performing the terminated portion of the work plus a fair and reasonable profit on such portion of the work, such profit shall not include anticipatory profit or consequential damages, less amounts paid or to be paid for accepted goods or services; provided that if it appears that the Contractor would have sustained a loss if the entire contract would have been completed, no profit shall be allowed or included and the amount of compensation shall be reduced to reflect the anticipated rate of loss;

(iii) Costs of settling and paying claims arising out of the termination of subcontracts or orders pursuant to paragraph 1 of this clause. These costs must not include costs paid in accordance with subparagraph (ii) above.

(iv) The reasonable settlement costs of the Contractor including accounting, legal, clerical, and other expenses reasonably necessary for the preparation of settlement claims and supporting data with respect to the terminated portion of the contract and for the termination of subcontracts thereunder, together with reasonable storage, transportation, and other costs incurred in connection with the protection or disposition of property allocable to the terminated portion of this contract. The total sum to be paid the Contractor under this subparagraph shall not exceed the total contract price plus the reasonable settlement cost of the Contractor reduced by the amount of payments otherwise made, the proceeds of any sales of supplies and manufacturing materials under subparagraph b of this paragraph, and the contract price of work not terminated.

d. Cost claimed, agreed to, or established under subparagraphs b and c shall be in accordance with chapter 3-123, HAR. bearing on such claim.

8.8 FINAL INSPECTION - Upon notice from the Contractor of the completion of the work or contract, the Director shall make an inspection. If the contract is found completed to the Director's satisfaction, such inspection shall constitute the final inspection and acceptance of the work.

If the work is unsatisfactory in whole or in part, the Director shall notify the Contractor of the work necessary for final completion and acceptance and the Contractor shall forthwith perform the work required by the Director. Upon performance of such required work by the Contractor, another inspection shall be made which shall constitute the final inspection if the work is completed satisfactorily.

Within ten (10) days after final inspection and acceptance of the work, or as soon thereafter as is practicable, the Contractor shall be notified by the Director in writing of such acceptance.

8.9 TERMINATION OF CONTRACTOR'S RESPONSIBILITY - The contract will be considered complete when all work has been completed, the final inspection made, the work accepted by the Director, and the final estimate paid. The Contractor will then be released from further obligation except as set forth in the contract and bond, when applicable.

## SECTION 9 - PAYMENT

9.1 SCOPE OF PAYMENT - The Contractor's bid price shall be inclusive of all costs, direct or indirect, including all taxes, required for the fulfillment of the contract.

Contract payments to the Contractor by the State shall be full payment for the furnishing of all labor, tools, equipment, and other incidentals, including all taxes, necessary for performing all work and services contemplated and embraced under the contract.

9.2 RETAINAGE/DEDUCTION FROM PAYMENT - The Director may at any time retain or deduct out of any sums due the Contractor to cover claims of the State against the Contractor, or such sums sufficient to cover any unpaid claims of others supported by sworn statements filed in the office of the Director, without any liability for damages, interest or otherwise to the Contractor for such retention or deduction.

Provided the work of the Contractor is progressing satisfactorily in the judgment of the Director and in accordance with the provisions of this contract, monthly payments, less five percent (5%), will be made to the Contractor. The amount of such monthly payments shall be determined by the Director based on the Director's estimate of the items of work performed and materials incorporated in the work and the value therefor at the unit prices or lump sum prices set forth in the contract. All monthly payments are shall be subject to correction at any time prior to or in the final payment.

At any time after fifty per cent (50%) of the work has been completed, if the State determines that the work contracted to be performed is progressing satisfactorily, the State may make any of the remaining monthly payments in full.

If the Director finds that unsatisfactory progress is being made, the State may, from the beginning of such unsatisfactory progress, withhold any amount up to five per cent (5%) of any subsequent monthly payment.

9.3 ASSIGNMENT OF PAYMENTS - All monies payable under the contract, or any part thereof, shall be paid to the Contractor in accordance with the provisions of this Section and no assignment or order executed by the Contractor directing payment of any portion or all of such funds to any other person or persons shall be recognized by the State unless such assignment or order specifies the amounts to be so paid and the purposes for which the assignment or order is given. Such assignment or order shall have attached thereto, by endorsement or otherwise, the consent of the surety, when

applicable. No such assignment or order shall be binding on the State.

Any assignment of money shall, however, be subject to all proper set-offs in favor of the State, to all deductions provided for in the contract and to all liens and rights conferred by law on the State. All money withheld, whether assigned or not, shall be subject to being used by the State for the completion of the work in the event of the Contractor's default.

9.4 PROGRESS PAYMENTS - Payments under this contract shall be made only upon submission by the Contractor of an original invoice and 2 copies. The invoice shall specify the amount due less retainage and shall also certify that services requested under the contract have been performed by the Contractor according to the contract.

9.5 FINAL PAYMENT - Final payment will only be made after the Contractor receives final acceptance by the Director as provided in Section 8.8, and until the Contractor has filed with the Department the following:

A. Consent of the surety, when applicable, to payment of the final estimate;

B. Satisfactory evidence by affidavit that all debts resulting from the contract have been fully paid or satisfactorily secured;

C. A current "Certificate of Vendor Compliance" issued by the Hawaii Compliance Express (HCE). The Certificate of Vendor Compliance is used to certify the Contractor's compliance with (a) Section 103D-328, HRS (for all contracts \$25,000 or more) which requires a current tax clearance certificate issued by the Hawaii State Department of Taxation and the Internal Revenue Service; (b) Chapters 383, 386, 392, and 393, HRS; and (c) Subsection 103D-310(c), HRS. The State reserves the right to verify that compliance is current prior to the issuance of final payment. Contractors are advised that non-compliance status will result in final payment being withheld until compliance is attained.

The filing of willfully false affidavits will disqualify the Contractor from bidding on future work of the Department.

3. Falsification of personnel qualifications shall constitute a major breach of this contract.

C. Availability

1. The Contractor shall furnish the State with telephone numbers of the place of business where a service technician can be called by the Director or a designate, every calendar day of the year to perform work under this Contract.
2. Personnel assigned to this job shall be available to respond to service or service or trouble calls within the parameters of these specifications.
3. The Contractor shall provide the State's District Manager and/or Maintenance Supervisors with a single point of contact for reporting problems and receiving reports on the progress of maintenance and other related work.

- 10.3 COORDINATION OF WORK - All work under this contract shall be coordinated with the State's Airports Manager at Hilo International Airport or his duly authorized Representative. Upon award of the contract, the Contractor shall give work schedules, parts requirements and other essential information concerning the Public Address System and Flight Information System at Hilo International Airport.

The Contractor shall also furnish the Airports Manager with telephone number of the single point of contact through which the Contractor can be called daily, including Saturdays, Sundays, and State holidays.

- 10.4 MAINTENANCE OF EQUIPMENT - The Contractor shall maintain the Public Address System and Flight Information System, IED) 500ACS Announcement Control System, including FAS, CAS, SCS, and VIS as specified in accordance with the specifications contained herein.

- 10.5 SYSTEM AVAILABILITY/FAILURE/MALFUNCTION

A. System availability will be considered as 100% when all components of the IED 500ACS including the Announcement Control System (ACS), the Flight Announcement System (FAS), the Courtesy Announcement System (CAS), the

SECTION 10 - GENERAL REQUIREMENTS

10.1 GENERAL - All work is subject to the requirements of Sections 1 to 9 inclusive, and this Section 10. By submitting a proposal of the work included in this contract, the Contractor shall be deemed to have made such examination, and is therefore familiar with the Innovative Electronics Designs (IED) 500ACS Announcement Control System (ACS), which includes the Flight Announcement System (FAS), the Courtesy Announcement System (CAS), the Security Checkpoint System (SCS), and the Visual Information System (VIS) at Hilo International Airport.

10.2 CONTRACTOR AND PERSONNEL QUALIFICATIONS, AND AVAILABILITY

A. Contractor Qualifications - Contractor shall have a minimum of three (3) consecutive year's experience, immediately prior to the bid opening date, in the field of electronic equipment maintenance service.

At the time of bidding, the Contractor is required to have a valid State of Hawaii "C-13" Electrical License and/or "C-15" Electronic Systems Contractor license, and factory certified and authorized by IED to provide service and maintenance for IED 500ACS.

B. Personnel Qualifications

1. Personnel assigned to this contract shall be:

a. Experienced electronic technicians with a minimum of two (2) years or 60 credit hours of formal academic training in analog and digital electronic theory;

b. Two (2) years of work experience in electronic maintenance in any of the specific fields listed in Section 10.2 A above; and

2. All prospective bidders must be able to produce documented training/certification and maintenance experience to substantiate their claims as indicated in Sections 10.2 A and 10.2 B.1 above.

Security Checkpoint System (SCS), and the Visual Information System (VIS) System are operating and functioning normally.

B. "Failure" will be defined as:

1. More than twenty (20) percent of the total zone of the ACS is not operating as designed; or
2. More than fifty (50) percent of any of the rest of the systems (FAS, CAS, SCS, and VIS) or equipment is down and not properly operating.

C. "Malfunction" will be defined as:

1. Less than twenty (20) percent of the total zone of the ACS is not operating as designed; or
2. Less than fifty (50) percent of any of the rest of the systems (FAS, CAS, SCS, and VIS) or equipment is down and not properly operating.

#### 10.6 SERVICE HOURS, RESPONSE TIMES, AND LIQUIDATED DAMAGES

A. The Contractor shall perform the maintenance activities during the normal working hours of 7:30 a.m. - 4:00 p.m., Monday - Friday except on State holidays. The Contractor shall sign in and sign out at the facilities maintenance office daily whenever any work is performed under this contract. The "hours" contained herein should not be construed to mean that all service requirements can be met in a daily eight (8) working hour period or by one technician.

B. Whenever the Contractor is called out to perform services during other than the hours set down in Section 10.6 A, it will be classified as "emergency service". Emergency service will be provided as needed at no additional cost to the State.

C. Response time as used in the following statements indicates the time between notification of the Contractor or designate (answering service, etc.) of a "failure" or "malfunction" and the time a service person arrives at the problem site prepared to deal with the "failure" or the time the service person dials-in to the system and starts to do the remote diagnostic measures to eliminate "failure" and "malfunction".

1. Two (2) hours to respond to a "failure" and four (4) hours to respond to a "malfunction" during the agreed hours of daily service.

2. Four (4) hours to respond to an "emergency" call out for a "failure" and Eight (8) hours to respond to an "emergency" call out for a "malfunction".

D. The total time for addressing a "failure" shall be 48 hours (response time inclusive) and 72 hours (response time inclusive) for a "malfunction".

E. Liquidated damages are defined in Proposal Page PF-1 and Section 8.6.

All corrective measures done in response to service or trouble calls shall be at no cost to the State unless the Contractor can substantiate to the satisfaction of the State that the trouble has been caused by abuse, vandalism, or natural disaster. In such cases, Contractor shall be paid for based on the time spent at the job site to complete the work. All trouble call tickets hours shall be certified and signed by an authorized representative of the State.

A log of and all State signed authorized trouble call tickets shall be submitted for the month as part of the monthly report with monthly billing as described in Section 10.12 A.

10.7 INSPECTION AND CORRECTION OF DEFECTS - A factory representative shall evaluate the overall condition of the system on an annual basis and shall also correct all discrepancies noted, install any applicable software updates and resolve hardware issues during the first quarter of this service contract. A report of the annual inspection and corrective actions maintained on site and submitted to the District Airport Manager and to the State Project Manager with the monthly billing as described per Section 11.

10.8 REPLACEMENT OF PARTS - The Contractor shall replace necessary parts of the system, which are worn through normal wear and tear at no cost to the State. Labor costs for removing old part and replace new part during the course of inspection and maintenance services shall be considered incidental to the Contractor's bid prices and no additional payment will be made by the State.

If the Contractor can substantiate that the replacement of parts is necessary due to damage by abuse, vandalism or natural disaster or the replacement of parts is not

covered under any specific provisions of this contract, the Contractor shall be reimbursed for the cost of the new parts, excluding taxes but including shipping charges, plus 20% for overhead, profit, taxes and other incidental expense. The Contractor shall substantiate his charges by submitting original billing as requested by the State.

Only parts that are new and correctly designed shall be used by the Contractor, and the Contractor shall maintain an inventory of spare parts or have available by air freight, so no breakdown will require more than forty-eight (48) hours to be corrected. Should a critical system component fail, the Contractor must be able to acquire advanced replacement parts (loaners) until the failed units are replaced.

10.9 TERMINATION OF CONTRACT AND WORK DONE BY OTHERS - The importance of the system functioning properly constantly demand that they be maintained in a satisfactory condition at all times.

A. Termination of Contract

1. If the system or equipment is in the "failure" condition for more than five (5) calendar days or the system is in the "malfunction" condition for more than ten (10) calendar days, the Contractor will be deemed to be in breach of contract and the State may unilaterally cancel the contract and/or take corrective action.
2. If the Contractor fails to respond to a call out for service within 36 hours, the Contractor will be deemed to be in breach of contract and the State may unilaterally cancel the contract and/or take corrective action.

B. Work Done by Others

1. Under the conditions of termination (Section 10.9 A), the State may take the necessary action to correct the malfunction(s) and deduct the cost of making the correction(s) from the Contractor's retainage.
2. If any of the system remains out of service for more than thirty (30) calendar days, the State may take action to correct same and deduct all cost to make the corrections from the Contract's retainage and/or

earned payments.

10.10 TERM OF CONTRACT - The term of this contract shall be for a three (3) month term beginning from the date indicated in the Notice to Proceed from the State.

10.11 MAINTENANCE RECORDS - The Contractor shall provide and maintain a maintenance schedule (from the original manufacturer) for each piece of equipment. Said schedule shall include a call back log which shall be presented to the Airport Manager upon request and shall include, but not be limited to:

- A. A complete record of all maintenance tasks: routine; preventive; and emergency maintenance which are performed on the system shall be maintained in separate maintenance log books or folders. The procedure for making entries into the maintenance log shall be submitted for approval by the State. The Contractor shall be responsible for insuring that the maintenance log is correctly updated.
- B. The Contractor shall maintain a written record of all Software installed on the system. The record shall include, at the minimum, version number and date of installation of each Software component.
- C. Contractor shall maintain two current system load functioning archival image backup of all computer harddrives of each computer of the Video Monitoring and Access Control System available requiring only the latest backup data restore for an immediate restoration of any harddisk failure.
- D. The Contractor shall complete a maintenance checklist, signed by the Airport Maintenance Superintendent certifying that the maintenance tasks have been completed. This checklist shall be submitted to the Airport Maintenance Superintendent and the State Project Manager on a monthly basis. The copy sent to the State Project Manager shall be submitted with the monthly invoices and shall serve as verification that the work has been satisfactorily completed.

- 10.12 ADVERTISEMENT FOR BIDS - The Contractor is advised that a contract similar in all essentials to this contract may be advertised for bids by the State so that bids will be received prior to thirty days before the expiration of the term of the contract as the same may be extended pursuant to Section 10.11. The Contractor may submit a bid in response to any such advertisement for bids upon compliance with the requirements thereof.
- 10.13 TRAINING AND CONTINUITY - Should the State elect to solicit bids for maintenance services, the Contractor shall provide a minimum of 14 days training period for two (2) personnel designated by the State. The training shall be conducted on-site. No additional payment shall be made to maintain this continuity.
- 10.14 MONTHLY INVOICES - One original invoice and one copy shall be submitted to the State Project Manager by the 15<sup>th</sup> of the month and shall include the signed completed maintenance log and individual service reports. Payment will be made to the Contractor at the contract unit price per service rendered as indicated in the Proposal Schedule. These prices shall be full compensation for furnishing all labor, materials, equipment, and incidentals necessary to complete the work.

The State shall withhold payment on any invoice missing any reports, certifications, checklists and/or proper documentation. All documentation shall be in the proper format in order for processing to proceed.

The State also reserves the right to withhold payment on any invoice if it has been determined that the performance is not in compliance with these specifications, up to standard, and/or if work has not been completed to the satisfaction of the State.

END OF SECTION

SECTION 11 MAINTENANCE PUBLIC ADDRESS SYSTEM AND  
FLIGHT INFORMATION SYSTEM

11.1 GENERAL

- A. All work is subject to the requirements of Sections 1 to 10 inclusive.
- B. The Contractor shall maintain the Innovative Electronics Designs (IED) 500ACS Announcement Control System (ACS), which includes the Flight Announcement System (FAS), the Courtesy Announcement System (CAS), the Security Checkpoint System (SCS), the Visual Information System (VIS), as well as the communications system for the various subsystems. Appendix A: Equipment list and Appendix B: Drawing shows the various components of the existing Public Address System and Flight Information System at Hilo International Airport.
- C. Contractor shall have technical support from Vendor's (IED) corporate offices for both hardware and software problems as they occur, and service or trouble calls shall be tracked and recorded until closed.

Contractor shall contract with Vendor to provide hardware and software maintenance / updates. This shall include software updates and upgrades as it becomes available. Vendor contracted support shall also provide priority 24/7/365 remote technical support.

- D. The Contractor shall work with the State's selected Flight Information Display System (FIDS) website vendor to provide data as the vendor requests.
- E. The Contractor shall guarantee that all services performed are of the quality necessary to assure performance in accordance with published specifications for that equipment.

11.2 SCOPE OF WORK

- A. ANNUAL PREVENTIVE MAINTENANCE - A factory representative shall perform a preventive maintenance service on an annual basis, where overall system condition will be evaluated, hardware issues will be resolved and any applicable software updates will be installed. As part of the annual preventive maintenance, the Contractor

shall create a complete backup of the system before leaving the site. A copy of this back-up shall be provided to the State and another copy shall be stored off-site by the Contractor to be used in the recovery procedures in the event of a system failure. The annual preventive maintenance required shall be completed during the first quarter of this contract.

The Contractor shall provide a record within two weeks to certify that the preventive maintenance was done. The record shall consist of work tickets, which shall contain identification and location of equipment, services performed, "as found" and "adjusted to" measurements.

Per the manufacturer's recommended inspection maintenance schedule, the Contractor shall also make adjustments and replacements of components as necessary to maintain the equipment in normal operating condition, from normal and proper usage. The Contractor is to provide an inspection maintenance checklist confirming completion of schedule items.

All parts and components which must be replaced as a result of preventive maintenance inspection or emergency service shall be at no additional cost to the State.

- B. MONTHLY MAINTENANCE - Contractor shall be paid on a monthly basis subject to receipt of acceptable Monthly Reports.

Monthly Reports shall include work reports for the particular month identifying every service or trouble calls, the nature of the problem, the time it was resolved and the person handling the call.

- C. SYSTEM SERVICE - The contractor shall have the Vendor support for the software and 500 ACS system via State provided high speed communication line.

Contractor and/or Vendor provide regular PDRP (Permanent Digital Record Playback) message library updates) as any new digital messages become available. In addition, Contractor and/or Vendor and will record up to five messages customized to Hilo International Airport at no additional cost.

- D. ANNUAL TRAINING - The Contractor shall contract with the Vendor to provide, on an annual basis, factory training for two (2) Hilo International Airport staff and the Contractor's technical staff at no additional cost.
- E. SCHEDULED EQUIPMENT REPLACEMENT - The Contractor shall contract with the Vendor to replace the entire system's existing electronic equipment with new equipment, equal or better, and install as follows:
1. Network Servers, Clients and Gateways (1 IEDO591R-S5 and 3 IEDO591D-clients) - replace within 90 days of commencement of year three of the Agreement.
  2. Hard drives in system dependent processors (2 IEDA510CPUs) - replace within 90 days of commencement of year three of the Agreement.
  3. Visual displays (34 IEDX900 displays (Contractor and Vendor to field verify existing size and count) - replace within year one of the Agreement.
- F. EXTENDED WARRANTY - As existing equipment is replaced with new equipment, the Contractor and Vendor shall provide a full extended warranty, both material and installation, for the new equipment for the entire remaining term of the Agreement.

END OF SECTION

STATE OF HAWAII  
DEPARTMENT OF TRANSPORTATION  
AIRPORTS

A P P E N D I X A

## APPENDIX A: EQUIPMENT LIST

Upgrade Public Address System – Hilo International Airport  
Section 16700: Integrated Public Address & Visual Paging System

Manufacturer's Catalog Data			
Qty	Model	Description	Reference
01	IEDA500ACS-L	ACS Mainframe System, 120VAC	
01	IED0591R	Rackmount Computer System	
01	IED0591SER	Redundant System Server	591SER/Dell 2950
01	IEDA510CPU	Redundant Online ACS CPU Card	
01	IEDA508T-1	ACS Microphone Station, Single, Telephone	
02	IEDT9160L	Titan DSP Amplifier Mainframe	
17	IEDT6472L	Titan Dual 200-Watt Amplifier Card	
01	IEDT9032NS	Titan Ambient Noise Sensor Collector	
27	IED0540S	Ambient Sensor – Unmounted	
11	IEDA528VFM-H	ACS Network Paging Station	
01	IEDA518SRM-H	ACS Rackmount Network Paging Station	
11	IEDA528VBB	ACS Mic Station Vertical Backbox	
01	IEDA510N	ACS Audio Network Card	
03	IED0590D	Computer System, Desktop	591TCAS
01	IED900XJ4888A	ProCurve Switch Mainframe, 4100gl Series	4148gl
01	IED900XJ4893A	ProCurve Mini-GBIC Module	
12	IED900XJ4858B	Procurve Gigabit SX-LC Mini-GBIC Module	
06	IED900XJ4900B	ProCurve 24-Port Switch	2626
07	IED900XBL6508	PowerSense Midspan POE Frame with with 8-port POE Module8-port POE Module	
26	IEDX900DDC	Display Processor (Includes 1 spare)	591DDC
01	IEDA500C&FT	ACS Mic Interface Card and Strip	
02	FMA44-36G	Atlas Sound Headend Equipment Rack	
06	900-19	Atlas Sound Netswitch Equipment Rack	
06	RAC-5	Atlas Sound Outlet Strip – 5 Outlets	
03	ASC-2A	Atlas Sound Outlet Strip – 12 (6 Duplex) Outlets	
1 lot		Vented Blank Panels, 2-Space	

**BH1543-53**

APPENDIX A, A-1

<b>Manufacturer's Catalog Data</b>			
<u>Qty</u>	<u>Model</u>	<u>Description</u>	<u>Reference</u>
1 lot		Vented Blank Panels, 1-Space	
04	SLR-3000P	Archtek Uninterruptible Power Supply	
01	SLR-1000P	Archtek Uninterruptible Power Supply	
25	LCD4010	NEC LCD Monitor, 40" w/extended warranty (Includes 1 spare)	
11	LCD3210	NEC LCD Monitor, 32" (Includes 1 spare)	
05	FSWT	Lucasey Flat Screen Wall Mount, Single Monitor	
24	FSUL2720	Lucasey Universal Adapter, Large	
06	FSDSCT20	Lucasey Flat Screen, Dbl Stud, Wall Mt, Arm	
04	FSCT	Lucasey Flat Screen, Ceiling Mount, Single Monitor	
04	CMAUSF15	Lucasey Channel Flange, 1-5/8"	
02	FSCTD	Lucasey Back to Back, Ceiling, Large Screen with Tilt	
02	PA150072	Lucasey Adjustable Pipe Columns, 1.5" NPT	
02	CMACC150	Lucasey Cathedral Ceiling Mount, 1.5" NPT	
02	CMACP150	Lucasey Pipe Coupling, 1.5" NPT	
02	CMASTA15	Lucasey Stabilizer Kit	
02	FSDSWP	Lucasey Flat Screen Dbl Stud, Wall Mt, Large	
10	LC200WA2	Lucasey Flat Screen, Wall Mount, up to 32"	
22	FSUSKW	Lucasey Security Kit	
25	MAC-251	Chief CPU Mounting Bracket	
27	SM590i	Soundtube Broadbeam Speakers	
113	RS600i	Soundtube Wall/Beam Speakers	
113	AC-RS-SM6	Soundtube Surface Mount Bracket	
169	CIS400	EAW Ceiling Speakers	
28	CS154	TOA Horns	
1 Lot	8451	Belden cable for ambient sensor, 1 pair, 22AWG, shielded, jacket	
1 Lot	8473	Belden cable for speakers, 1 pair, 14AWG, unshielded, jacket	
1 Lot	7851A	Belden Category 6 cable	

**BH1543-53**

APPENDIX A, A-2

STATE OF HAWAII  
DEPARTMENT OF TRANSPORTATION  
AIRPORTS

A P P E N D I X B

# Airports Division

DEPARTMENT OF TRANSPORTATION  
STATE OF HAWAII

PLANS FOR

## MAINTENANCE OF PUBLIC ADDRESS AND FLIGHT INFORMATION SYSTEMS

AT  
HILO INTERNATIONAL AIRPORT  
HILO, HAWAII

PROJECT NO. **BH1543-53**

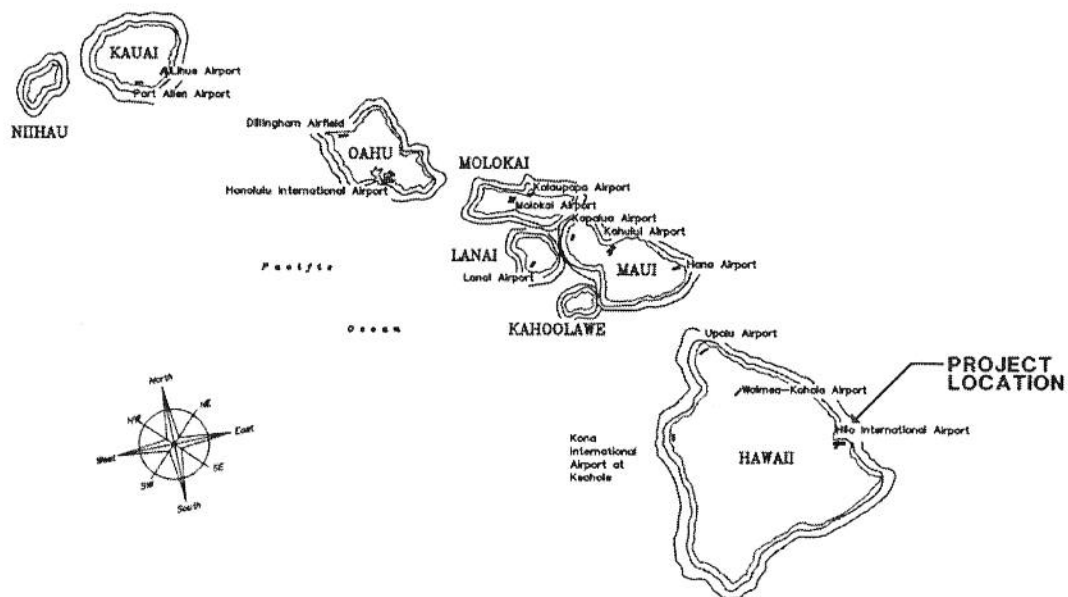

MAINTENANCE OF PUBLIC ADDRESS  
AND FLIGHT INFORMATION SYSTEMS  
HILO INTERNATIONAL AIRPORT  
PROJECT NO.: **BH1543-53**

DATE:  
**SEP 2020**

SHEET NO.:  
1

BH1423-53  
APPENDIX B, B-1

BH1423-53  
APPENDIX B, B-2

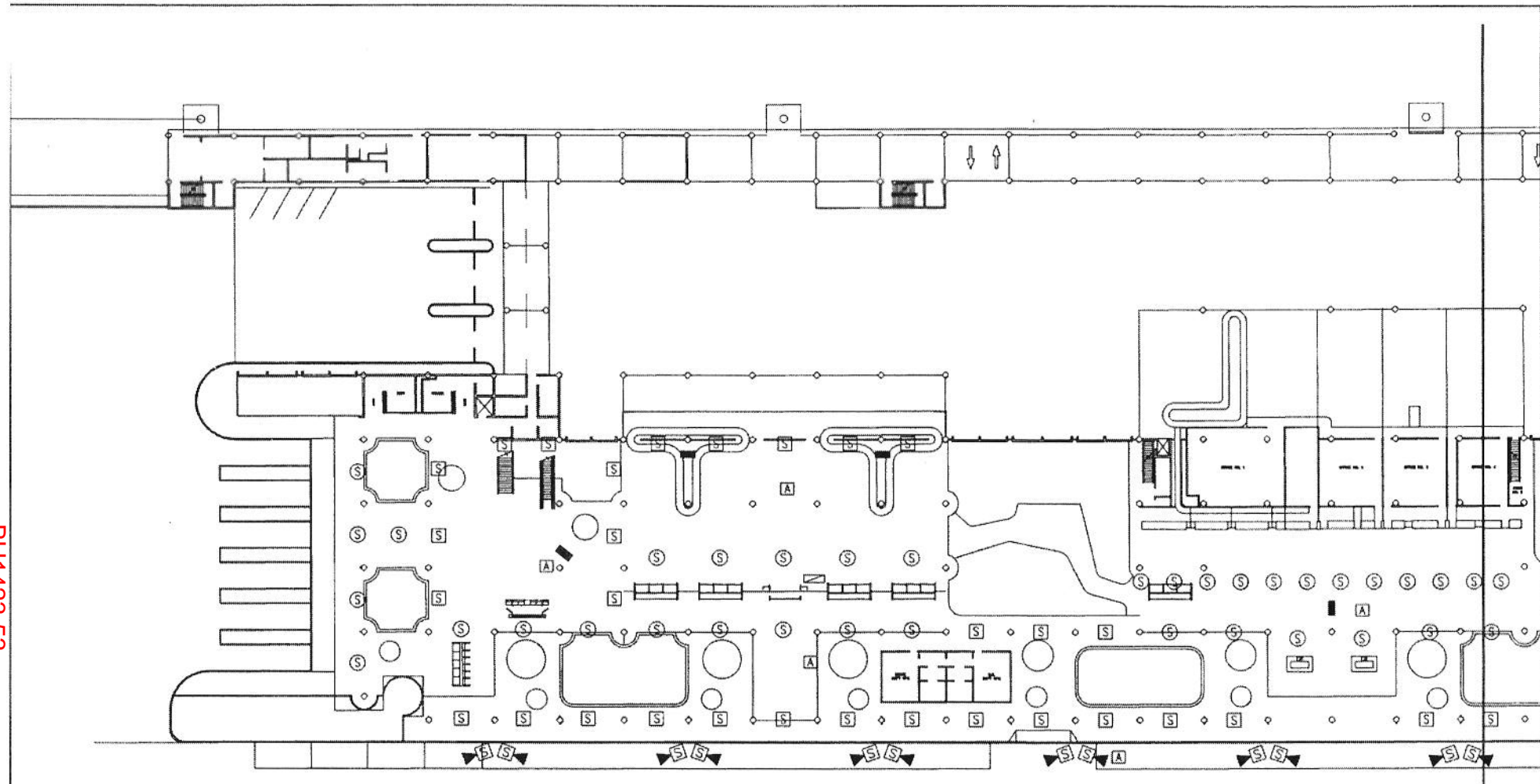

**SYMBOL LIST**

- LCD DISPLAY W/ PROCESSOR
- S IN-CEILING SPEAKER
- S OPEN-CEILING SPEAKER, SURFACE MOUNT
- S  WIDE RANGE SPEAKER
- M DIGITAL PAGE STATION
- M D DESKTOP DIGITAL PAGE STATION AND COURTESY ANNOUNCEMENT WORKSTATION
- A AMBIENT NOISE SENSOR

PARTIAL GROUND LEVEL PLAN

MAINTENANCE OF PUBLIC ADDRESS AND FLIGHT INFORMATION SYSTEMS HILO INTERNATIONAL AIRPORT PROJECT NO.: <b>BH1543-53</b>	
DATE: <b>SEP 2020</b>	SHEET NO.: 2

BH1423-53  
APPENDIX B, B-3

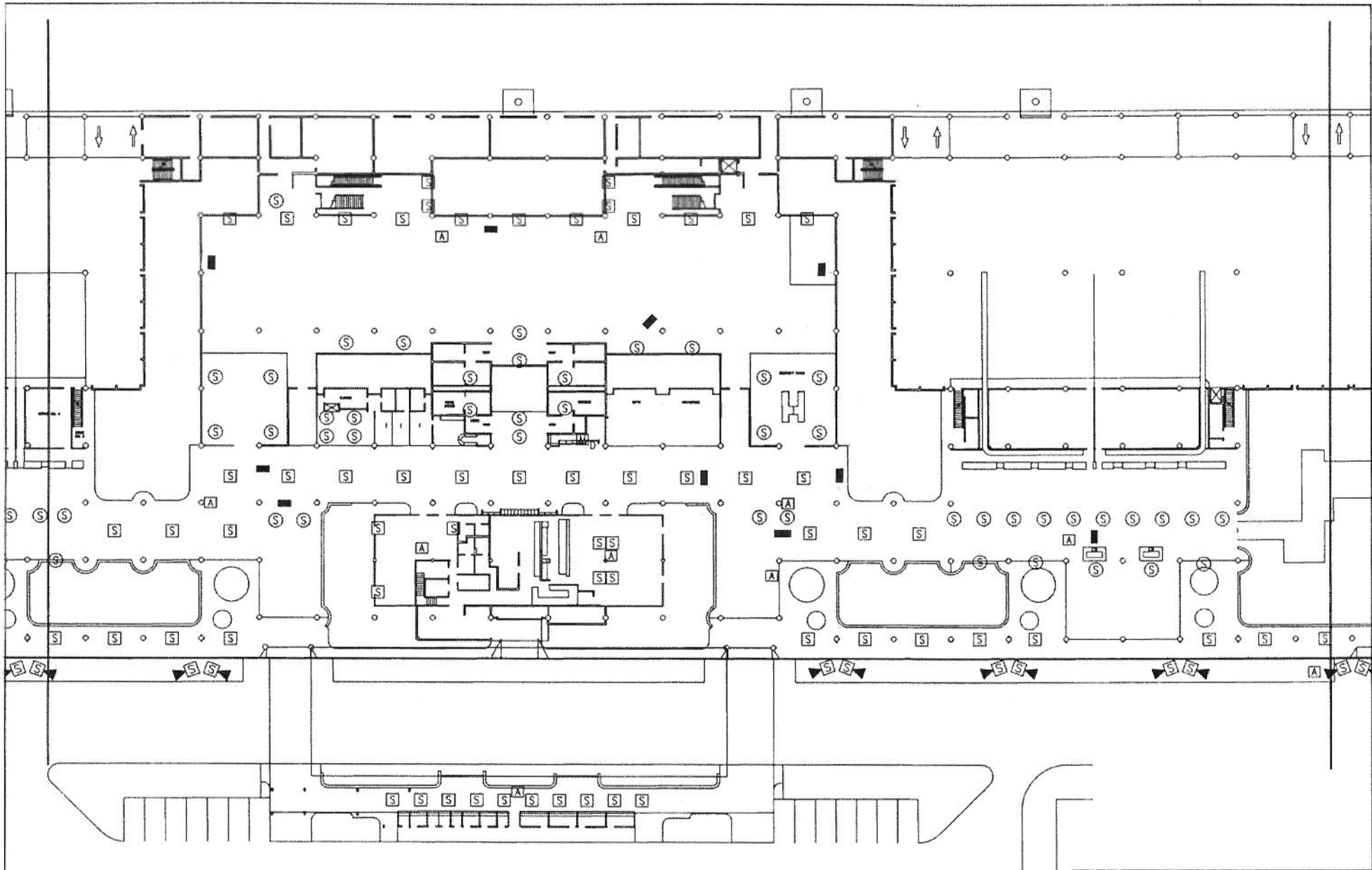

PARTIAL GROUND LEVEL PLAN

MAINTENANCE OF PUBLIC ADDRESS  
AND FLIGHT INFORMATION SYSTEMS  
HILO INTERNATIONAL AIRPORT  
PROJECT NO.: BH1543-53

DATE:  
SEP 2020

SHEET NO.:  
3

BH1423-53  
APPENDIX B, B-4

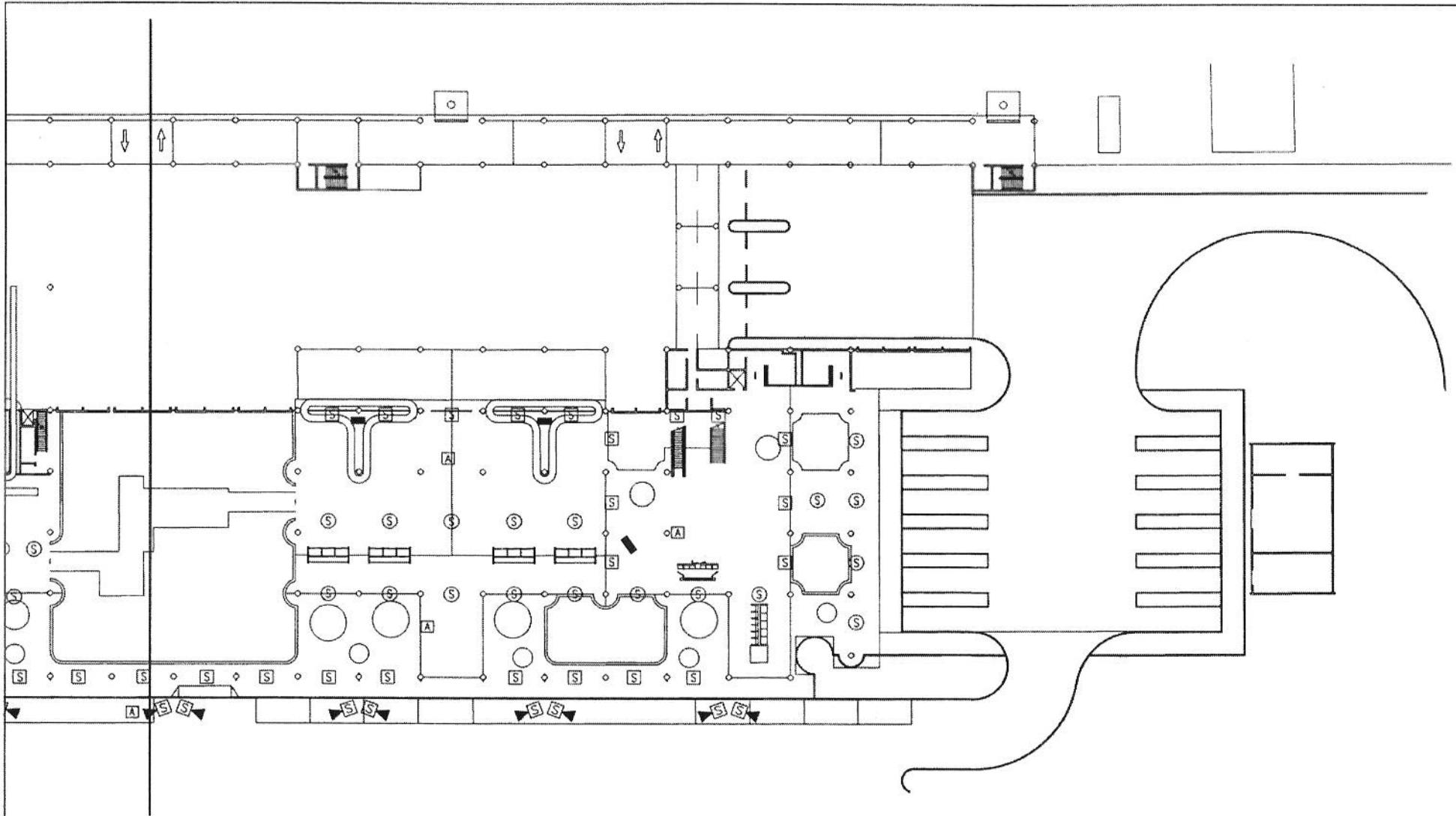

PARTIAL GROUND LEVEL PLAN

FOOTNOTE:

EQUIPMENT SHOWN ON THIS SHEET 4 IS CURRENTLY OFFLINE AND IS TEMPORARILY STORED IN THE ERR. THESE ARE IN SCOPE OF WORK. EQUIPMENT STORED: (3) DDC UNITS AND (3) 40" MONITORS.

MAINTENANCE OF PUBLIC ADDRESS  
AND FLIGHT INFORMATION SYSTEMS  
HILO INTERNATIONAL AIRPORT  
PROJECT NO.: **BH1543-53**

DATE:  
**SEP 2020**

SHEET NO.:  
4

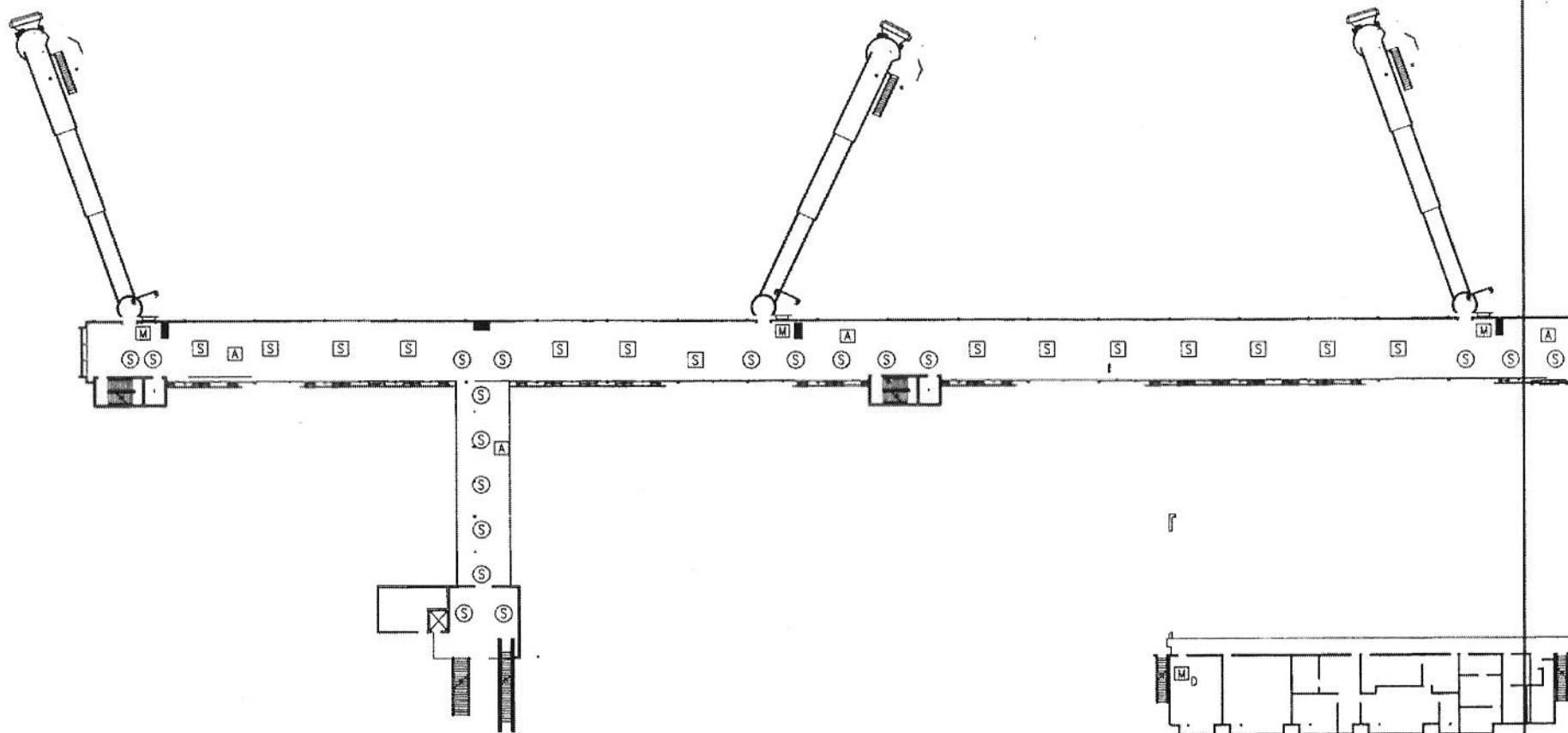

PARTIAL SECOND LEVEL PLAN

MAINTENANCE OF PUBLIC ADDRESS  
AND FLIGHT INFORMATION SYSTEMS  
HILO INTERNATIONAL AIRPORT  
PROJECT NO.: **BH1543-53**

DATE: <b>SEP 2020</b>	SHEET NO.: <b>5</b>
--------------------------	------------------------

BH1423-53  
APPENDIX B, B-6

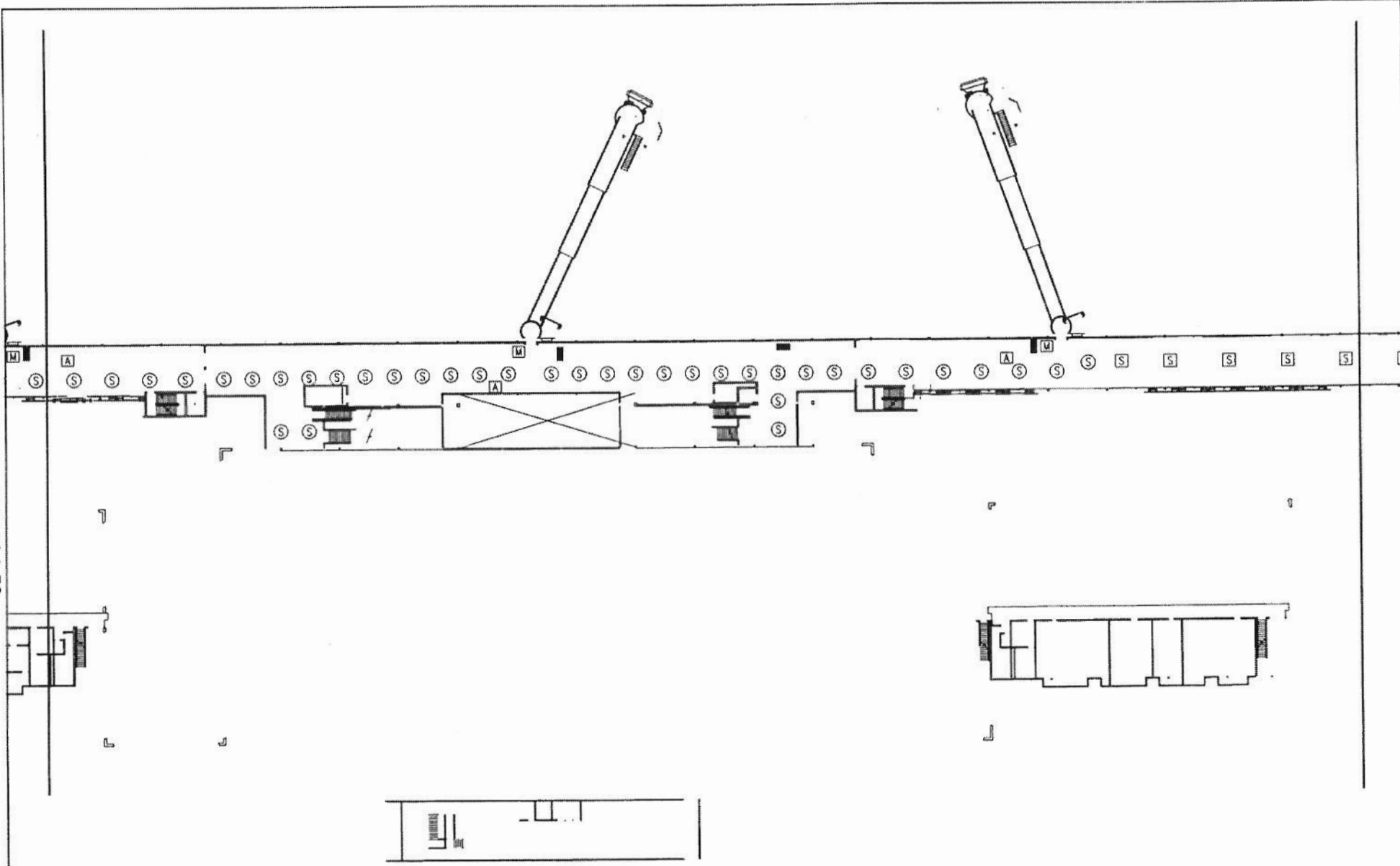

PARTIAL SECOND LEVEL PLAN

MAINTENANCE OF PUBLIC ADDRESS AND FLIGHT INFORMATION SYSTEMS HILO INTERNATIONAL AIRPORT PROJECT NO.: <b>BH1543-53</b>	
DATE: <b>SEP 2020</b>	SHEET NO.: <b>6</b>

BH1423-53  
APPENDIX B, B-7

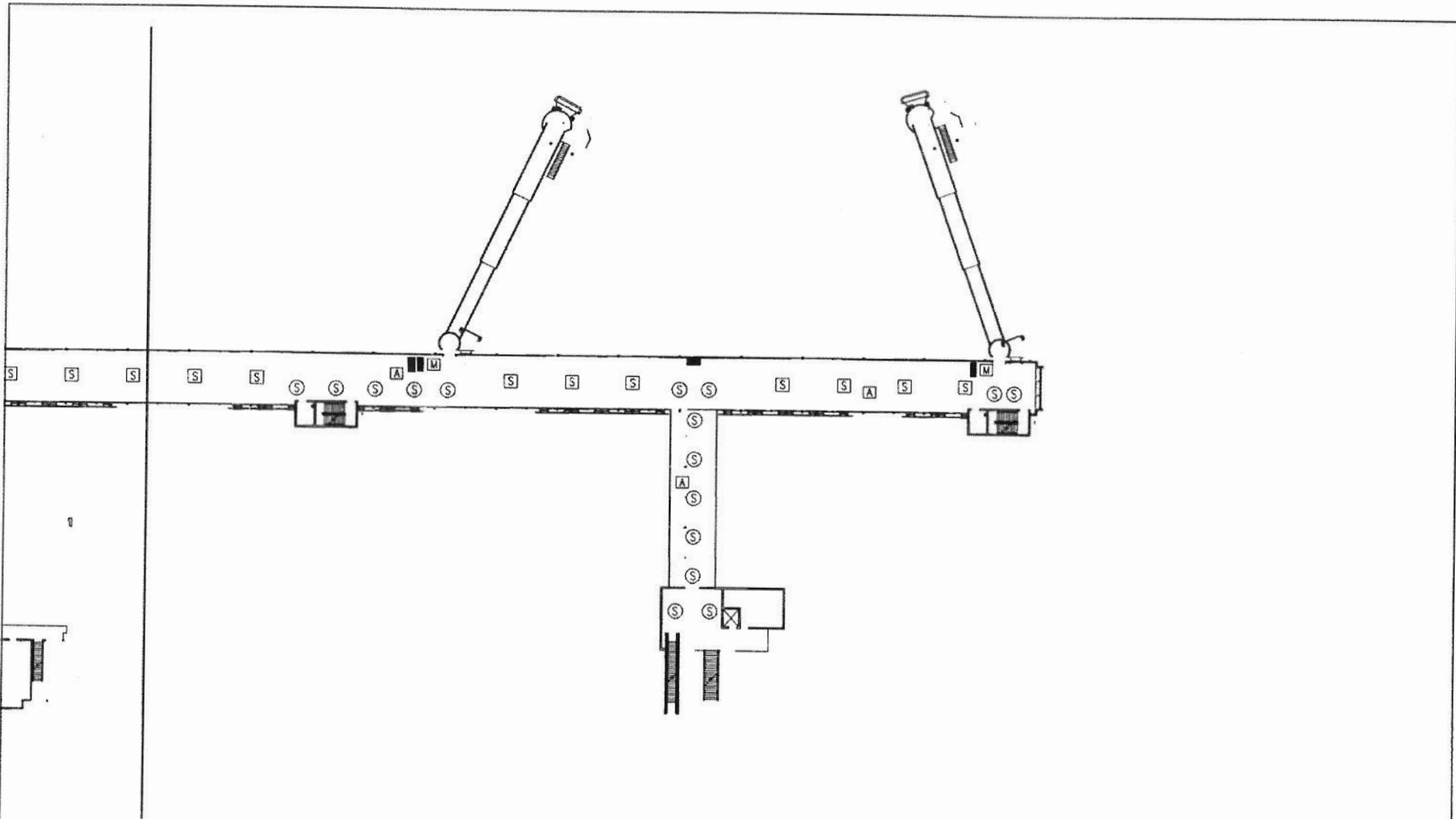

PARTIAL SECOND LEVEL PLAN

FOOTNOTE:  
EQUIPMENT SHOWN ON THIS SHEET 7 IS CURRENTLY OFFLINE AND IS TEMPORARILY STORED IN THE ERR. THESE ARE IN SCOPE OF WORK. EQUIPMENT STORED: (3) DDC UNITS, (2) 32" MONITORS, (2) 40" MONITORS, AND (2) DIGITAL PAGE STATIONS.

MAINTENANCE OF PUBLIC ADDRESS AND FLIGHT INFORMATION SYSTEMS HILO INTERNATIONAL AIRPORT PROJECT NO.: <b>BH1543-53</b>	
DATE: <b>SEP 2020</b>	SHEET NO.: 7

STATE OF HAWAII  
DEPARTMENT OF TRANSPORTATION  
AIRPORTS

P R O P O S A L

PROPOSAL TO THE STATE OF HAWAII  
DEPARTMENT OF TRANSPORTATION  
AIRPORTS

PROJECT: Maintenance of Public Address and Flight Information Systems  
Hilo International Airport  
Hilo, Hawaii

PROJECT NUMBER: BH1543-53

TERM OF CONTRACT: Contract is for a term of three (3) months commencing from the date indicated in the Notice to Proceed from the State.

LIQUIDATED DAMAGES: For failure to meet response time to a "failure" (Section 10.6 C.1) - \$60.00/hr. and fraction thereof.

For failure to meet response time to a "malfunction" (Section 10.6 C.1) - \$30.00/hr. and fraction thereof.

For failure to meet response time to a "failure" for an emergency call out (Section 10.6 C.2) - \$60.00/hr.

For failure to meet response time to a "malfunction" for an emergency call out (Section 10.6 C.2) - \$30.00/hr.

For failure to eliminate a "failure" condition (Section 10.6 D) within the allotted time shall be one hundred dollars (\$100.00) plus 1/30 of the Contractor's monthly bid price to maintain the Public Address System for each additional twenty-four (24) hour period or fraction thereof.

For failure to eliminate a "malfunction" condition (Section 10.6 D) within the allotted time shall be sixty dollars (\$60.00) plus 1/30 of the Contractor's monthly bid price to maintain the Public Address System for each additional twenty-four (24) hour period or fraction thereof.

ELECTRONIC SUBMITTAL: **Bidders shall submit and upload the complete proposal to HIEPRO prior to the bid opening date and time. Any additional support documents explicitly designated as**

confidential and/or proprietary shall be uploaded as a separate file to HiePRO. See SPECIAL PROVISIONS 2.4 DELIVERY OF PROPOSALS for complete details. FAILURE TO UPLOAD THE COMPLETE PROPOSAL TO HiePRO SHALL BE GROUNDS FOR REJECTION OF THE BID.

NOTE: BID, PERFORMANCE AND PAYMENT BONDS ARE NOT REQUIRED FOR THIS PROJECT.

Director of Transportation  
Aliiainmoku Hale  
869 Punchbowl Street  
Honolulu, Hawaii 96813

Dear Sir:

The undersigned bidder declares the following:

1. It has not, either directly or indirectly, entered into any agreement, participated in any collusion, or otherwise taken any action in restraint of free competitive bidding in connection with this proposal.
2. It has not been assisted or represented on this matter by any individual who has, in a State capacity, been involved in the subject matter of this contract within the past two years.
3. It has not and will not, either directly or indirectly offered or given a gratuity (i.e. an entertainment or gift) to any State or County employee to obtain a contract or favorable treatment under a contract.

The undersigned bidder further agrees to the following:

1. If this proposal is accepted, it shall execute a contract with the Department to provide all necessary labor, machinery, tools, equipment, apparatus and any other means of construction, to do all the work and to furnish all the materials specified in the contract in the manner and within the time therein prescribed in the contract, and that it shall accept in full payment therefore the sum of the unit and/or lump sum prices as set forth in the attached proposal schedule for the actual quantities of work performed and materials furnished and furnish satisfactory security in accordance with Section 103D-324, Hawaii Revised Statutes, within 10 days after the award of the contract or within such time as the Director of Transportation may allow after the undersigned has received the contract documents for execution, and is fully aware that non-compliance with the aforementioned terms will result in the forfeiture of the full amount of the bid guarantee required under Section 103D-323, Hawaii Revised Statutes.

2. That the quantities given in the attached proposal schedule are approximate only and are intended principally to serve as a guide in determining and comparing the bids.
3. That the Department does not either expressly or by implication, agree that the actual amount of work will correspond therewith, but reserves the right to increase or decrease the amount of any class or portion of the work, or to omit portions of the work, as may be deemed necessary or advisable by the Director of Transportation, and that all increased or decreased quantities of work shall be performed at the unit prices set forth in the attached proposal schedule except as provided for in the specifications.
4. In case of a discrepancy between unit prices and the totals in said Proposal Schedule, the unit prices shall prevail.
5. Agrees to begin work within 10 working days after the date of notification to commence with the work, which date is in the notice to proceed, and shall finish the entire project within the time prescribed.
6. The Director of Transportation reserves the right to reject any or all bids and to waive any defects when in the Director's opinion such rejections or waiver will be for the best interest of the public.

Receipt is hereby acknowledged and complete examination is hereby expressly guaranteed of the following listed items: the specifications, the notice to bidders, the special provisions, if any, the proposal, the plans, if any, and the contract form.

The undersigned acknowledges receipt of any addendum, issued by recording in the space below the date of receipt.

Addendum No. 1 \_\_\_\_\_ Addendum No. 3 \_\_\_\_\_

Addendum No. 2 \_\_\_\_\_ Addendum No. 4 \_\_\_\_\_

The undersigned hereby certifies that the bid prices contained in the attached proposal schedule have been carefully checked and are submitted as correct, final and are net prices.

\_\_\_\_\_  
Bidder (Company Name)

By \_\_\_\_\_  
Authorized Signature

\_\_\_\_\_  
Print Name and Title

\_\_\_\_\_  
Business Address

\_\_\_\_\_  
Business Telephone      Email

\_\_\_\_\_  
Date

\_\_\_\_\_  
Contact Person (If different from above)

Phone: \_\_\_\_\_ Email: \_\_\_\_\_

NOTE:

If bidder is a CORPORATION, the legal name of the corporation shall be set forth above, the corporate seal affixed, together with the signature(s) of the officer(s) authorized to sign contracts on behalf of the corporation. Please attach to this page current (not more than six months old) evidence of the authority of the officer(s) to sign on behalf of the corporation.

If bidder is a PARTNERSHIP, the true name of the partnership shall be set forth above with the signature(s) of the general partner(s) authorized to sign contracts on behalf of the partnership. Please attach to this page current (not more than six months old) evidence of the authority of the partner(s) to sign on behalf of the partnership.

If bidder is an INDIVIDUAL, the bidder's signature shall be placed in the space provided therefore on page PF-4.

If signature is by an agent, other than an officer of a corporation or a partner of a partnership, a POWER OF ATTORNEY must be on file with the Department prior to the opening of bids or submitted with the bid; otherwise, the bid may be rejected as irregular and unauthorized.

PROPOSAL SCHEDULE

MAINTENANCE OF PUBLIC ADDRESS AND FLIGHT INFORMATION SYSTEMS  
HILO INTERNATIONAL AIRPORT  
PROJECT NO. BH1543-53

Item (a)	Description (b)	Qty (c)	Unit	Unit Price (d)	Total (cxd)
1.	Monthly Maintenance of Public Address (PAS) & Flight Information System (FIS) and IED (Vendor) Technical Support	3	months	\$ _____	\$ _____
2	Replacement of parts damaged by natural disaster, abuse, or vandalism	Allowance			\$ <u>          \$5,000.00</u>
3	Regular working hours per man-hr. (technician) for work done caused by natural disaster, abuse or vandalism	20	hours	\$ _____	\$ _____
4	Spare parts purchases	Allowance			\$ <u>          \$5,000.00</u>
<b>TOTAL AMOUNT FOR COMPARISON OF BIDS</b>					<b>\$ _____</b>

NOTES:

- 1 Bids shall include all Federal, State, County, and other applicable taxes.
- 2 The TOTAL AMOUNT FOR COMPARISON OF BIDS shall be used to determine the lowest responsible bidder.
- 3 Bidders shall complete all unit bid prices and amounts. Failure to do so shall be grounds for rejection of bid.
- 4 In case of a discrepancy between unit prices and the total in said bid, the unit price shall prevail.
- 5 The equipment listed in these specifications shall not be construed as being complete and accurate.
- 6 Payment(s) to the Contractor shall be made on the basis of actual number of service(s) performed or material supplied and the unit price.
- 7 Refer to Sections 10 and 11 for requirements for servicing the airport paging system and flight information systems.
- 8 **Bidders shall submit and upload the complete proposal to HiePRO prior to the bid opening date and time. Proposals received after said due date and time shall not be considered. Original (wet ink, hard copy) proposal documents are not required to be submitted. Contract award shall be based on evaluation of proposals submitted and uploaded to HiePRO. Any additional documents explicitly designated as confidential and/or proprietary shall be uploaded as a separate file to HiePRO. Do not include confidential and/or proprietary**

---

Item (a)	Description (b)	Qty (c)	Unit	Unit Price (d)	Total (exd)
-------------	--------------------	------------	------	-------------------	----------------

---

**documents with the proposal. The record of each bidder and respective bid shall be open to public inspection.**

**FAILURE TO UPLOAD THE COMPLETE PROPOSAL TO HIePRO SHALL BE GROUNDS FOR REJECTION OF THE BID.**

If there is a conflict between the specification document and the HIePRO solicitation, the specifications shall govern and control unless otherwise specified.